



GDP/GLP 40-55VX

SPEC SHEET

4,000 - 5,500 kg

VX Series

Diesel and LPG
Forklift Trucks

TRUCK DIMENSIONS – VX SERIES

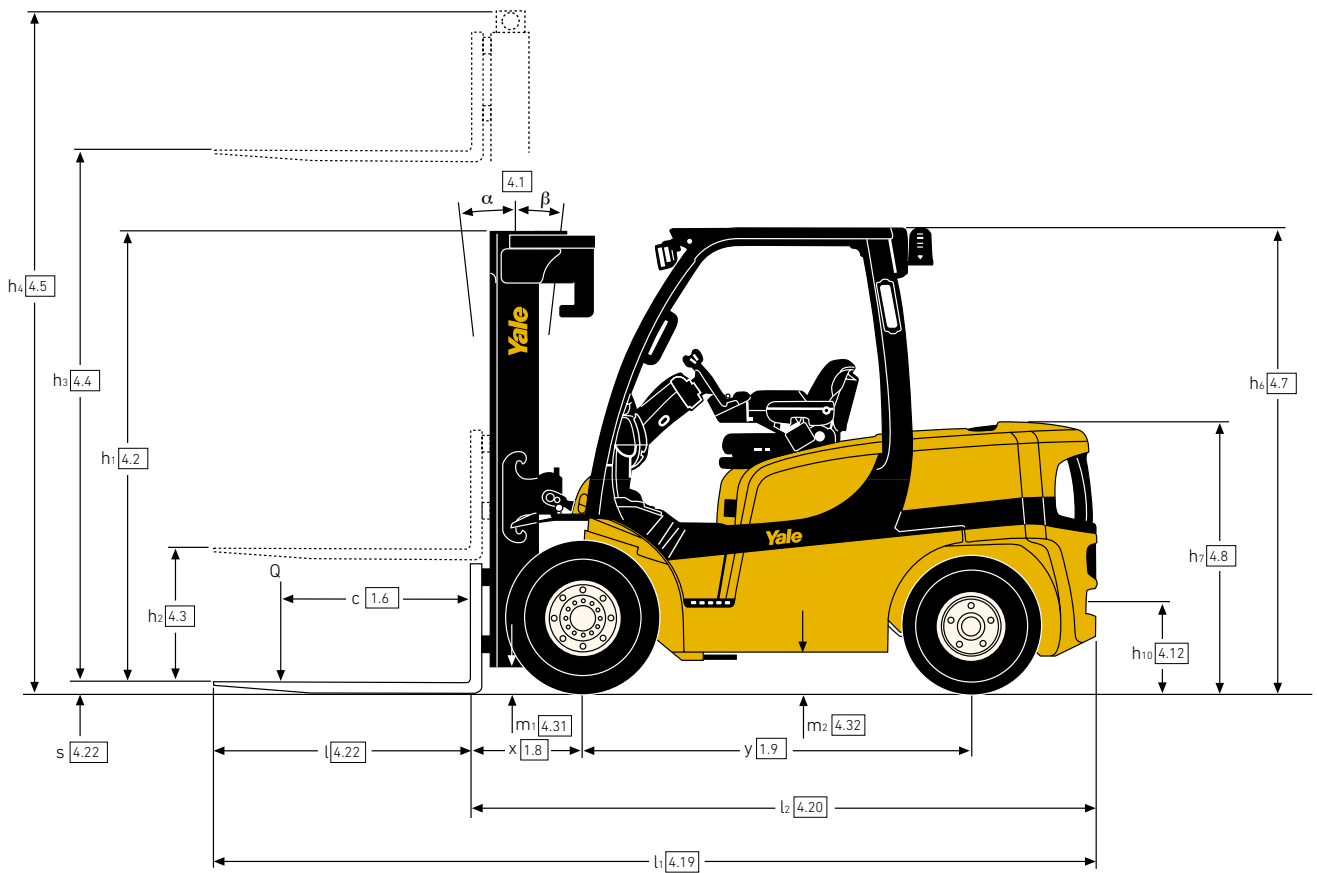

TRUCK DIMENSIONS – VX SERIES

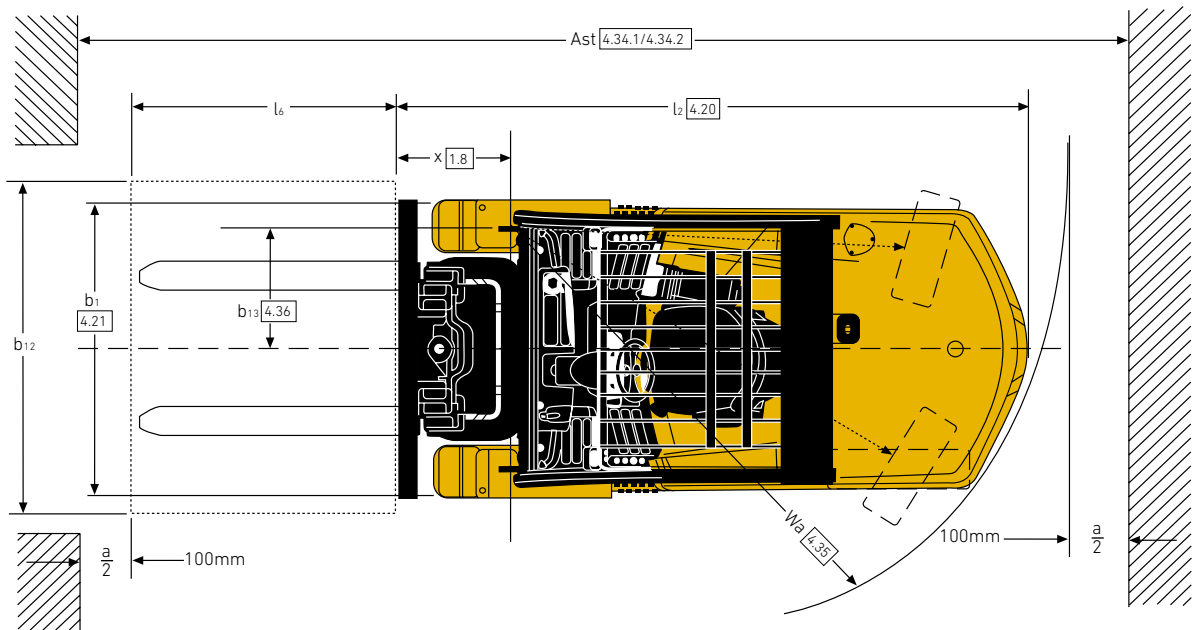

VDI 2198 – GENERAL SPECIFICATIONS – VX SERIES

		Yale				
		GLP 40 VX5	GLP 40 VX6			
GENERAL	1.1	Manufacturer				
	1.2	Model designation				
	1.3	Drive				
	1.3.1	Engine				
	1.3.2	Transmission				
	1.3.3	Brake Type				
	1.4	Operator type				
	1.5	Rated capacity/rated load	Q (t)			
	1.6	Load centre distance	c (mm)	500		
	1.8	Load distance, centre of drive axle to fork	x (mm)	522.6		
1.8.1	Load distance, centre of drive axle to fork (ISS Carriage)	x (mm)	555			
1.9	Wheelbase	y (mm)	1830			
WEIGHT	2.1	Service weight	kg	6264	6470	
	2.2	Axle loading laden, front/rear	kg	8969/1295	9133/1337	
	2.3	Axle loading unladen, front/rear	kg	2733/3531	2678/3792	
TYRES	3.1	Tyres, front/rear	Superelastic			
	3.2	Tyre size, front	250x15			
	3.3	Tyre size, rear	7.00x12			
	3.5	Number of wheels, front/rear (X = driven)	2x / 2			
	3.6	Tread, front	b ₁₀ (mm)	1152		
	3.7	Tread, rear	b ₁₁ (mm)	1136		
	DIMENSIONS	4.1	Tilt of mast/fork carriage forward/backward	α / β (°)		
4.2		Height, mast lowered	h ₁ (mm)			
4.3		Free lift ⁽¹⁾	h ₂ (mm)			
4.4		Lift ⁽¹⁾	h ₃ (mm)			
4.5		Height, mast extended ⁽²⁾	h ₄ (mm)			
4.7		Height of overhead guard (cabin)	h ₆ (mm)			
4.8		Seat height/stand height ⁽³⁾	h ₇ (mm)			
4.12		Coupling height	h ₁₀ (mm)	429	0	
4.19		Overall length	l ₁ (mm)	3946	3977	
4.20		Length to face of forks (Standard Carriage)	l ₂ (mm)	2946	2977	
4.20.1		Length to face of forks (Integrated Side Shift Carriage)	l ₂ (mm)	2978	3009	
4.21		Overall width (single / wide / dual)	b ₁ /b ₂ (mm)	1402 / 1485 / 1773		
4.22		Fork dimensions ISO 2331	s/e/l (mm)	50 / 120 / 1000	50 / 120 / 1200	
4.23		Fork carriage ISO 2328, class/type A, B	IIIA			
4.24		Fork carriage width (Standard Carriage) ⁽⁴⁾	b ₃ (mm)	1219	0	
4.24.1		Fork carriage width (ISS Carriage) ⁽⁴⁾	b ₃ (mm)	1219		
4.31		Ground clearance, laden, below mast	m ₁ (mm)	151		
4.32		Ground clearance, centre of wheelbase	m ₂ (mm)	194		
4.33		Load dimension b ₁₂ × l ₆ crossways	b ₁₂ × l ₆ (mm)	1200 × 1000		
4.34		Aisle width predetermined load dimensions ⁽⁵⁾	Ast (mm)	4293	4322	
4.34.1		Aisle width for pallets 1000 × 1200 crossways ⁽⁵⁾	Ast (mm)	4493	4522	
4.34.2		Aisle width for pallets 800 × 1200 crossways ⁽⁵⁾	Ast (mm)	4493	4522	
4.35		Turning radius	Wa (mm)	2570	2599	
4.36	Internal turning radius	b ₁₃ (mm)	751			
4.36.1	90° intersecting aisle (with pallet W = 1200mm x L = 1000mm)	(mm)	2298	2314		
4.36.2	Step Height (from ground to running board)	(mm)	441			
4.36.3	Step Height (between intermediate steps and floor)	(mm)	360			
PERFORMANCE	5.1	Travel speed, laden/unladen	19.9 / 20.5	24.8 / 25.3	19.9 / 20.4	24.8 / 25.3
	5.1.1	Travel speed, laden/unladen, backwards	19.9 / 20.5		19.9 / 20.4	
	5.2	Lift speed, laden/unladen	m/s			
	5.3	Lowering speed, laden/unladen	m/s			
	5.5	Drawbar pull, laden/unladen ⁽⁶⁾	N			
	5.7	Gradeability, laden/unladen ⁽⁷⁾	%			
	5.9	Acceleration time, laden/unladen	s			
	5.10	Service brake	Hydraulic			
	ENGINE	7.1	Engine manufacturer/type	Kubota WG3800		
		7.2	Engine power according to ISO 1585	kW		
7.3		Rated speed	min-1			
7.3.1		Torque at 1/min	Nm/min-1			
7.4		Number of cylinders/displacement	cm3			
7.5		Fuel consumption according to VDI cycle	l/h or kg/h			
7.10		Battery voltage/nominal capacity ⁽⁸⁾	V/Ah			
OTHER	8.1	Type of drive unit	Hydrodynamic			
	10.1	Operating pressure for attachments	bar			
	10.2	Oil volume for attachments ⁽⁹⁾	l/min			
	10.3	Hydraulic oil tank, capacity	l			
	10.4	Fuel tank, capacity	l			
	10.7	Sound pressure level at the driver's seat ^{(10) (11)}	dB (A)			
	10.7.1	Sound power level during the workcycle ⁽¹²⁾	dB (A)			
	10.7.2	Guaranteed sound power 2001/14/EC	dB (A)			
	10.8	Towing coupling, type DIN	Pin			

(1) Top of forks

(2) Add 32mm with load backrest

(3) Full suspension seat in depressed position

(4) Without load backrest, add 32mm with load backrest

(5) Stacking aisle width (lines 4.34 & 4.34.1 & 4.34.2) are based on the V.D.I. standard calculation as shown on illustration. The British Industrial Truck Association recommends the addition of 100 mm to the total clearance (dimension a) for extra operating margin at the rear of the truck

(6) At 1.6 km/h

VDI 2198 – GENERAL SPECIFICATIONS – VX SERIES

		Yale		
		GLP 45S VX5	GLP 45S VX6	
GENERAL	1.1	Manufacturer		
	1.2	Model designation		
	1.3	Drive		
	1.3.1	Engine		
	1.3.2	Transmission		
	1.3.3	Brake Type		
	1.4	Operator type		
	1.5	Rated capacity/rated load		
	1.6	Load centre distance	Seated	
	1.8	Load distance, centre of drive axle to fork	Premium Oil Immersed Brakes	
WEIGHT	2.1	Service weight		
	2.2	Axle loading laden, front/rear		
	2.3	Axle loading unladen, front/rear		
	3.1	Tyres, front/rear		
	3.2	Tyre size, front		
	3.3	Tyre size, rear		
	3.5	Number of wheels, front/rear (X = driven)		
	3.6	Tread, front	Superelastic	
	3.7	Tread, rear		
	DIMENSIONS	4.1	Tilt of mast/fork carriage forward/backward	
4.2		Height, mast lowered		
4.3		Free lift ⁽¹⁾		
4.4		Lift ⁽¹⁾		
4.5		Height, mast extended ⁽²⁾		
4.7		Height of overhead guard (cabin)		
4.8		Seat height/stand height ⁽³⁾		
4.12		Coupling height		
4.19		Overall length		
4.20		Length to face of forks (Standard Carriage)		
4.20.1		Length to face of forks (Integrated Side Shift Carriage)		
4.21		Overall width (single / wide / dual)		
4.22		Fork dimensions ISO 2331		
4.23		Fork carriage ISO 2328, class/type A, B		
4.24		Fork carriage width (Standard Carriage) ⁽⁴⁾		
4.24.1		Fork carriage width (ISS Carriage) ⁽⁴⁾		
4.31		Ground clearance, laden, below mast		
4.32		Ground clearance, centre of wheelbase		
4.33		Load dimension b ₁₂ × l ₆ crossways		
4.34		Aisle width predetermined load dimensions ⁽⁵⁾		
4.34.1	Aisle width for pallets 1000 × 1200 crossways ⁽⁵⁾			
4.34.2	Aisle width for pallets 800 × 1200 crossways ⁽⁵⁾			
4.35	Turning radius			
4.36	Internal turning radius			
4.36.1	90° intersecting aisle (with pallet W = 1200mm x L = 1000mm)			
4.36.2	Step Height (from ground to running board)			
4.36.3	Step Height (between intermediate steps and floor)			
PERFORMANCE	5.1	Travel speed, laden/unladen		
	5.1.1	Travel speed, laden/unladen, backwards		
	5.2	Lift speed, laden/unladen		
	5.3	Lowering speed, laden/unladen		
	5.5	Drawbar pull, laden/unladen ⁽⁶⁾		
	5.7	Gradeability, laden/unladen ⁽⁷⁾		
	5.9	Acceleration time, laden/unladen		
	5.10	Service brake		
	ENGINE	7.1	Engine manufacturer/type	
		7.2	Engine power according to ISO 1585	
7.3		Rated speed		
7.3.1		Torque at 1/min		
7.4		Number of cylinders/displacement		
7.5		Fuel consumption according to VDI cycle		
7.10		Battery voltage/nominal capacity ⁽⁸⁾		
OTHER	8.1	Type of drive unit		
	10.1	Operating pressure for attachments		
	10.2	Oil volume for attachments ⁽⁹⁾		
	10.3	Hydraulic oil tank, capacity		
	10.4	Fuel tank, capacity		
	10.7	Sound pressure level at the driver's seat ^{(10) (11)}		
	10.7.1	Sound power level during the workcycle ⁽¹²⁾		
	10.7.2	Guaranteed sound power 2001/14/EC		
	10.8	Towing coupling, type DIN		

(7) At 4.8km/h. Gradeability figures are provided for comparison of tractive performance, but are not intended to endorse the operation of the vehicle on the stated inclines. Follow instructions in the operating manual regarding operation on inclines

(8) Battery ampere hour (Ah) nominal capacity ratings are estimated

(9) Variable

(10) With and without cab

(11) LPAZ, Measured according to the test cycles and based on the weighting values contained in EN12053

(12) LWAZ, Measured according to the test cycles and based on the weighting values contained in EN12053

All values are nominal values and they are subject to tolerances.

VDI 2198 – GENERAL SPECIFICATIONS – VX SERIES

		Yale					
		GLP 50S VX5	GLP 50 VX6				
GENERAL	1.1	Manufacturer					
	1.2	Model designation					
	1.3	Drive					
	1.3.1	Engine					
	1.3.2	Transmission					
	1.3.3	Brake Type					
	1.4	Operator type					
	1.5	Rated capacity/rated load	Q (t)				
	1.6	Load centre distance	c (mm)	500			
	1.8	Load distance, centre of drive axle to fork	x (mm)	590.6			
1.8.1	Load distance, centre of drive axle to fork (ISS Carriage)	x (mm)	608				
1.9	Wheelbase	y (mm)	2100				
WEIGHT	2.1	Service weight	kg	7027	7520		
	2.2	Axle loading laden, front/rear	kg	10789/1237	11041/1478		
	2.3	Axle loading unladen, front/rear	kg	3192/3835	3206/4314		
TYRES	3.1	Tyres, front/rear	Superelastic				
	3.2	Tyre size, front	300x15				
	3.3	Tyre size, rear	28x9-15				
	3.5	Number of wheels, front/rear (X = driven)	2x / 2				
	3.6	Tread, front	b ₁₀ (mm)	1150			
	3.7	Tread, rear	b ₁₁ (mm)	1162			
	DIMENSIONS	4.1	Tilt of mast/fork carriage forward/backward	α / β (°)			
4.2		Height, mast lowered	h ₁ (mm)	2215			
4.3		Free lift ⁽¹⁾	h ₂ (mm)	100			
4.4		Lift ⁽¹⁾	h ₃ (mm)	2740			
4.5		Height, mast extended ⁽²⁾	h ₄ (mm)	3730			
4.7		Height of overhead guard (cabin)	h ₅ (mm)	2300			
4.8		Seat height/stand height ⁽³⁾	h ₇ (mm)	1321			
4.12		Coupling height	h ₁₀ (mm)	0			
4.19		Overall length	l ₁ (mm)	4500			
4.20		Length to face of forks (Standard Carriage)	l ₂ (mm)	3300			
4.20.1		Length to face of forks (Integrated Side Shift Carriage)	l ₂ (mm)	3317			
4.21		Overall width (single / wide / dual)	b ₁ /b ₂ (mm)	1450 / 1575 / 1875			
4.22		Fork dimensions ISO 2331	s/e/l (mm)	60 / 150 / 1200			
4.23		Fork carriage ISO 2328, class/type A, B		IVA			
4.24		Fork carriage width (Standard Carriage) ⁽⁴⁾	b ₃ (mm)	0			
4.24.1		Fork carriage width (ISS Carriage) ⁽⁴⁾	b ₃ (mm)	1372			
4.31		Ground clearance, laden, below mast	m ₁ (mm)	194			
4.32		Ground clearance, centre of wheelbase	m ₂ (mm)	237			
4.33		Load dimension b ₁₂ × l ₆ crossways	b ₁₂ × l ₆ (mm)	1200 × 1000			
4.34		Aisle width predetermined load dimensions ⁽⁵⁾	Ast (mm)	4668			
4.34.1		Aisle width for pallets 1000 × 1200 crossways ⁽⁵⁾	Ast (mm)	4868			
4.34.2		Aisle width for pallets 800 × 1200 crossways ⁽⁵⁾	Ast (mm)	4868			
4.35		Turning radius	Wa (mm)	2877			
4.36	Internal turning radius	b ₁₃ (mm)	800				
4.36.1	90° intersecting aisle (with pallet W = 1200mm × L = 1000mm)	(mm)	2469				
4.36.2	Step Height (from ground to running board)	(mm)	441				
4.36.3	Step Height (between intermediate steps and floor)	(mm)	360				
PERFORMANCE	5.1	Travel speed, laden/unladen	km/h	18.7 / 19.2	23.2 / 23.9		
	5.1.1	Travel speed, laden/unladen, backwards	km/h	18.7 / 19.2			
	5.2	Lift speed, laden/unladen	m/s	0.45 / 0.46			
	5.3	Lowering speed, laden/unladen	m/s	0.51 / 0.42			
	5.5	Drawbar pull, laden/unladen ⁽⁶⁾	N	29575/18399	35348/18399	29575/18399	35348/18399
	5.7	Gradeability, laden/unladen ⁽⁷⁾	%	25.2/26.5	30.6/26.5	25.2/26.5	30.6/26.5
	5.9	Acceleration time, laden/unladen	s	5.3/4.4	5.3/4.5	5.3/4.4	5.3/4.5
	5.10	Service brake	Hydraulic				
	ENGINE	7.1	Engine manufacturer/type	Kubota WG3800			
		7.2	Engine power according to ISO 1585	kW	64		
7.3		Rated speed	min-1	2200			
7.3.1		Torque at 1/min	Nm/min-1	300 / 1200			
7.4		Number of cylinders/displacement	cm3	4 / 3769			
7.5		Fuel consumption according to VDI cycle	l/h or kg/h	5.0	5.1	5.0	5.1
7.10		Battery voltage/nominal capacity ⁽⁸⁾	V/Ah	12 / 105			
OTHER	8.1	Type of drive unit	Hydrodynamic				
	10.1	Operating pressure for attachments	bar	155			
	10.2	Oil volume for attachments ⁽⁹⁾	l/min	83.3			
	10.3	Hydraulic oil tank, capacity	l	67.8			
	10.4	Fuel tank, capacity	l	38.6			
	10.7	Sound pressure level at the driver's seat ^{(10) (11)}	dB (A)	79			
	10.7.1	Sound power level during the workcycle ⁽¹²⁾	dB (A)	99			
	10.7.2	Guaranteed sound power 2001/14/EC	dB (A)	103			
	10.8	Towing coupling, type DIN		Pin			

(1) Top of forks

(2) Add 32mm with load backrest

(3) Full suspension seat in depressed position

(4) Without load backrest, add 32mm with load backrest

(5) Stacking aisle width (lines 4.34 & 4.34.1 & 4.34.2) are based on the V.D.I. standard calculation as shown on illustration. The British Industrial Truck Association recommends the addition of 100 mm to the total clearance (dimension a) for extra operating margin at the rear of the truck

(6) At 1.6 km/h

VDI 2198 – GENERAL SPECIFICATIONS – VX SERIES

GENERAL	1.1	Manufacturer		Yale	
	1.2	Model designation		GLP 55 VX6	
	1.3	Drive		LPG	
	1.3.1	Engine		Kubota 3.8L LPG	
	1.3.2	Transmission		Techtronix 1, 1-Speed Techtronix 2, 2-Speed	
	1.3.3	Brake Type		Premium Oil Immersed Brakes	
	1.4	Operator type		Seated	
	1.5	Rated capacity/rated load	Q (t)	5.5	
	1.6	Load centre distance	c (mm)	600	
	1.8	Load distance, centre of drive axle to fork	x (mm)	590.6	
1.8.1	Load distance, centre of drive axle to fork (ISS Carriage)	x (mm)	608		
1.9	Wheelbase	y (mm)	2100		
WEIGHT	2.1	Service weight	kg	7811	
	2.2	Axle loading laden, front/rear	kg	11754/1558	
	2.3	Axle loading unladen, front/rear	kg	3134/4677	
TYRES	3.1	Tyres, front/rear		Superelastic	
	3.2	Tyre size, front		300x15	
	3.3	Tyre size, rear		28x9-15	
	3.5	Number of wheels, front/rear (X = driven)		2x / 2	
	3.6	Tread, front	b ₁₀ (mm)	1150	
	3.7	Tread, rear	b ₁₁ (mm)	1162	
	DIMENSIONS	4.1	Tilt of mast/fork carriage forward/backward	α / β (°)	6 / 10
4.2		Height, mast lowered	h ₁ (mm)	2215	
4.3		Free lift ⁽¹⁾	h ₂ (mm)	100	
4.4		Lift ⁽¹⁾	h ₃ (mm)	2740	
4.5		Height, mast extended ⁽²⁾	h ₄ (mm)	3730	
4.7		Height of overhead guard (cabin)	h ₅ (mm)	2300	
4.8		Seat height/stand height ⁽³⁾	h ₇ (mm)	1321	
4.12		Coupling height	h ₁₀ (mm)	0	
4.19		Overall length	l ₁ (mm)	4541	
4.20		Length to face of forks (Standard Carriage)	l ₂ (mm)	3341	
4.20.1		Length to face of forks (Integrated Side Shift Carriage)	l ₂ (mm)	3358	
4.21		Overall width (single / wide / dual)	b ₁ /b ₂ (mm)	1450 / 1575 / 1875	
4.22		Fork dimensions ISO 2331	s/e/l (mm)	60 / 150 / 1200	
4.23		Fork carriage ISO 2328, class/type A, B		IVA	
4.24		Fork carriage width (Standard Carriage) ⁽⁴⁾	b ₃ (mm)	0	
4.24.1		Fork carriage width (ISS Carriage) ⁽⁴⁾	b ₃ (mm)	1372	
4.31		Ground clearance, laden, below mast	m ₁ (mm)	194	
4.32		Ground clearance, centre of wheelbase	m ₂ (mm)	237	
4.33		Load dimension b ₁₂ × l ₆ crossways	b ₁₂ × l ₆ (mm)	1200 × 1000	
4.34		Aisle width predetermined load dimensions ⁽⁵⁾	Ast (mm)	4706	
4.34.1		Aisle width for pallets 1000 × 1200 crossways ⁽⁵⁾	Ast (mm)	4906	
4.34.2		Aisle width for pallets 800 × 1200 crossways ⁽⁵⁾	Ast (mm)	4906	
4.35		Turning radius	Wa (mm)	2915	
4.36	Internal turning radius	b ₁₃ (mm)	800		
4.36.1	90° intersecting aisle (with pallet W = 1200mm x L = 1000mm)	(mm)	2490		
4.36.2	Step Height (from ground to running board)	(mm)	441		
4.36.3	Step Height (between intermediate steps and floor)	(mm)	360		
PERFORMANCE	5.1	Travel speed, laden/unladen	km/h	18.6 / 19.2 23 / 23.9	
	5.1.1	Travel speed, laden/unladen, backwards	km/h	18.6 / 19.2	
	5.2	Lift speed, laden/unladen	m/s	0.45 / 0.46	
	5.3	Lowering speed, laden/unladen	m/s	0.51 / 0.42	
	5.5	Drawbar pull, laden/unladen ⁽⁶⁾	N	29419/17976 35192/17976	
	5.7	Gradeability, laden/unladen ⁽⁷⁾	%	23.5/24.8 28.5/24.8	
	5.9	Acceleration time, laden/unladen	s	5.4/4.4 5.5/4.5	
	5.10	Service brake		Hydraulic	
	ENGINE	7.1	Engine manufacturer/type		Kubota WG3800
		7.2	Engine power according to ISO 1585	kW	64
7.3		Rated speed	min-1	2200	
7.3.1		Torque at 1/min	Nm/min-1	300 / 1200	
7.4		Number of cylinders/displacement	cm3	4 / 3769	
7.5		Fuel consumption according to VDI cycle	l/h or kg/h	5.2 5.3	
7.10		Battery voltage/nominal capacity ⁽⁸⁾	V/Ah	12 / 105	
OTHER	8.1	Type of drive unit		Hydrodynamic	
	10.1	Operating pressure for attachments	bar	155	
	10.2	Oil volume for attachments ⁽⁹⁾	l/min	83.3	
	10.3	Hydraulic oil tank, capacity	l	67.8	
	10.4	Fuel tank, capacity	l	38.6	
	10.7	Sound pressure level at the driver's seat ^{(10) (11)}	dB (A)	79	
	10.7.1	Sound power level during the workcycle ⁽¹²⁾	dB (A)	99	
	10.7.2	Guaranteed sound power 2001/14/EC	dB (A)	103	
	10.8	Towing coupling, type DIN		Pin	

(7) At 4.8km/h. Gradeability figures are provided for comparison of tractive performance, but are not intended to endorse the operation of the vehicle on the stated inclines. Follow instructions in the operating manual regarding operation on inclines

(8) Battery ampere hour (Ah) nominal capacity ratings are estimated

(9) Variable

(10) With and without cab

(11) LPAZ, Measured according to the test cycles and based on the weighting values contained in EN12053

(12) LWAZ, Measured according to the test cycles and based on the weighting values contained in EN12053

All values are nominal values and they are subject to tolerances.

VDI 2198 – GENERAL SPECIFICATIONS – VX SERIES

		Yale					
		GDP 40 VX5	GDP 40 VX6				
GENERAL	1.1	Manufacturer					
	1.2	Model designation					
	1.3	Drive					
	1.3.1	Engine					
	1.3.2	Transmission					
	1.3.3	Brake Type					
	1.4	Operator type					
	1.5	Rated capacity/rated load	Q (t)				
	1.6	Load centre distance	c (mm)	500			
	1.8	Load distance, centre of drive axle to fork	x (mm)	522.6			
1.8.1	Load distance, centre of drive axle to fork (ISS Carriage)	x (mm)	555				
1.9	Wheelbase	y (mm)	1830				
WEIGHT	2.1	Service weight	kg	6264	6470		
	2.2	Axle loading laden, front/rear	kg	8969/1295	9133/1337		
	2.3	Axle loading unladen, front/rear	kg	2733/3531	2678/3792		
TYRES	3.1	Tyres, front/rear	Superelastic				
	3.2	Tyre size, front	250x15				
	3.3	Tyre size, rear	7.00x12				
	3.5	Number of wheels, front/rear (X = driven)	2x / 2				
	3.6	Tread, front	b ₁₀ (mm)	1152			
	3.7	Tread, rear	b ₁₁ (mm)	1136			
	DIMENSIONS	4.1	Tilt of mast/fork carriage forward/backward	α / β (°)			
4.2		Height, mast lowered	h ₁ (mm)				
4.3		Free lift ⁽¹⁾	h ₂ (mm)				
4.4		Lift ⁽¹⁾	h ₃ (mm)				
4.5		Height, mast extended ⁽²⁾	h ₄ (mm)				
4.7		Height of overhead guard (cabin)	h ₆ (mm)				
4.8		Seat height/stand height ⁽³⁾	h ₇ (mm)				
4.12		Coupling height	h ₁₀ (mm)	429	0		
4.19		Overall length	l ₁ (mm)	3946	3977		
4.20		Length to face of forks (Standard Carriage)	l ₂ (mm)	2946	2977		
4.20.1		Length to face of forks (Integrated Side Shift Carriage)	l ₂ (mm)	2978	3009		
4.21		Overall width (single / wide / dual)	b ₁ /b ₂ (mm)	1402 / 1485 / 1773			
4.22		Fork dimensions ISO 2331	s/e/l (mm)	50 / 120 / 1000	50 / 120 / 1200		
4.23		Fork carriage ISO 2328, class/type A, B	IIIA				
4.24		Fork carriage width (Standard Carriage) ⁽⁴⁾	b ₃ (mm)	1219	0		
4.24.1		Fork carriage width (ISS Carriage) ⁽⁴⁾	b ₃ (mm)	1219			
4.31		Ground clearance, laden, below mast	m ₁ (mm)	151			
4.32		Ground clearance, centre of wheelbase	m ₂ (mm)	194			
4.33		Load dimension b ₁₂ × l ₆ crossways	b ₁₂ × l ₆ (mm)	1200 × 1000			
4.34		Aisle width predetermined load dimensions ⁽⁵⁾	Ast (mm)	4293	4322		
4.34.1		Aisle width for pallets 1000 × 1200 crossways ⁽⁵⁾	Ast (mm)	4493	4522		
4.34.2		Aisle width for pallets 800 × 1200 crossways ⁽⁵⁾	Ast (mm)	4493	4522		
4.35		Turning radius	Wa (mm)	2570	2599		
4.36	Internal turning radius	b ₁₃ (mm)	751				
4.36.1	90° intersecting aisle (with pallet W = 1200mm x L = 1000mm)	(mm)	2298	2314			
4.36.2	Step Height (from ground to running board)	(mm)	441				
4.36.3	Step Height (between intermediate steps and floor)	(mm)	360				
PERFORMANCE	5.1	Travel speed, laden/unladen	19.9 / 20.5	24.9 / 25.4	19.9 / 20.5	24.9 / 25.3	
	5.1.1	Travel speed, laden/unladen, backwards	19.9 / 20.5				
	5.2	Lift speed, laden/unladen	0.62 / 0.63				
	5.3	Lowering speed, laden/unladen	0.55 / 0.47				
	5.5	Drawbar pull, laden/unladen ⁽⁶⁾	N	25676/15616	30744/15616	25636/15292	30704/15292
	5.7	Gradeability, laden/unladen ⁽⁷⁾	%	26.9/27.2	32.8/27.2	26.3/25.7	32/25.7
	5.9	Acceleration time, laden/unladen	s	5/4.2	5.2/4.3	5.1/4.2	5.2/4.4
	5.10	Service brake	Hydraulic				
	ENGINE	7.1	Engine manufacturer/type	Kubota V3800 E4			
		7.2	Engine power according to ISO 1585	kW			
7.3		Rated speed	min-1				
7.3.1		Torque at 1/min	Nm/min-1				
7.4		Number of cylinders/displacement	cm3				
7.5		Fuel consumption according to VDI cycle	l/h or kg/h				
7.10		Battery voltage/nominal capacity ⁽⁸⁾	V/Ah				
OTHER	8.1	Type of drive unit	Hydrodynamic				
	10.1	Operating pressure for attachments	bar				
	10.2	Oil volume for attachments ⁽⁹⁾	l/min				
	10.3	Hydraulic oil tank, capacity	l				
	10.4	Fuel tank, capacity	l				
	10.7	Sound pressure level at the driver's seat ^{(10) (11)}	dB (A)				
	10.7.1	Sound power level during the workcycle ⁽¹²⁾	dB (A)				
	10.7.2	Guaranteed sound power 2001/14/EC	dB (A)				
	10.8	Towing coupling, type DIN	Pin				

(1) Top of forks

(2) Add 32mm with load backrest

(3) Full suspension seat in depressed position

(4) Without load backrest, add 32mm with load backrest

(5) Stacking aisle width (lines 4.34 & 4.34.1 & 4.34.2) are based on the V.D.I. standard calculation as shown on illustration. The British Industrial Truck Association recommends the addition of 100 mm to the total clearance (dimension a) for extra operating margin at the rear of the truck

(6) At 1.6 km/h

VDI 2198 – GENERAL SPECIFICATIONS – VX SERIES

		Yale					
		GDP 45S VX5	GDP 45S VX6				
GENERAL	1.1	Manufacturer					
	1.2	Model designation					
	1.3	Drive					
	1.3.1	Engine					
	1.3.2	Transmission					
	1.3.3	Brake Type					
	1.4	Operator type					
	1.5	Rated capacity/rated load	Seated				
	1.6	Load centre distance	500	600			
	1.8	Load distance, centre of drive axle to fork	590.6				
1.8.1	Load distance, centre of drive axle to fork (ISS Carriage)	608					
1.9	Wheelbase	1830	2100				
WEIGHT	2.1	Service weight	6826	7027			
	2.2	Axle loading laden, front/rear	10114/1212	10244/1283			
	2.3	Axle loading unladen, front/rear	2931/3895	3195/3835			
TYRES	3.1	Tyres, front/rear					
	3.2	Tyre size, front	250x15	300x15			
	3.3	Tyre size, rear	7.00x12	28x9-15			
	3.5	Number of wheels, front/rear (X = driven)	2x / 2				
	3.6	Tread, front	b ₁₀ (mm)	1152	1150		
	3.7	Tread, rear	b ₁₁ (mm)	1136	1162		
	DIMENSIONS	4.1	Tilt of mast/fork carriage forward/backward	α / β (°)			
4.2		Height, mast lowered	h ₁ (mm)				
4.3		Free lift ⁽¹⁾	h ₂ (mm)				
4.4		Lift ⁽¹⁾	h ₃ (mm)				
4.5		Height, mast extended ⁽²⁾	h ₄ (mm)				
4.7		Height of overhead guard (cabin)	2258	2300			
4.8		Seat height/stand height ⁽³⁾	1279	1321			
4.12		Coupling height	h ₁₀ (mm)				
4.19		Overall length	l ₁ (mm)	4266	4457		
4.20		Length to face of forks (Standard Carriage)	l ₂ (mm)	3066	3257		
4.20.1		Length to face of forks (Integrated Side Shift Carriage)	l ₂ (mm)	3083	3274		
4.21		Overall width (single / wide / dual)	b ₁ /b ₂ (mm)	1402 / 1485 / 1773	1450 / 1575 / 1875		
4.22		Fork dimensions ISO 2331	s/e/l (mm)	60 / 150 / 1200			
4.23		Fork carriage ISO 2328, class/type A, B	IVA				
4.24		Fork carriage width (Standard Carriage) ⁽⁴⁾	b ₃ (mm)	0			
4.24.1		Fork carriage width (ISS Carriage) ⁽⁴⁾	b ₃ (mm)	1219	1372		
4.31		Ground clearance, laden, below mast	m ₁ (mm)	151			
4.32		Ground clearance, centre of wheelbase	m ₂ (mm)	194			
4.33		Load dimension b ₁₂ × l ₆ crossways	b ₁₂ × l ₆ (mm)	1200 × 1000			
4.34		Aisle width predetermined load dimensions ⁽⁵⁾	Ast (mm)	4342	4628		
4.34.1		Aisle width for pallets 1000 × 1200 crossways ⁽⁵⁾	Ast (mm)	4542	4828		
4.34.2		Aisle width for pallets 800 × 1200 crossways ⁽⁵⁾	Ast (mm)	4542	4828		
4.35		Turning radius	Wa (mm)	2619	2837		
4.36	Internal turning radius	b ₁₃ (mm)	751	800			
4.36.1	90° intersecting aisle (with pallet W = 1200mm x L = 1000mm)	(mm)	2332	2447			
4.36.2	Step Height (from ground to running board)	(mm)	441				
4.36.3	Step Height (between intermediate steps and floor)	(mm)	360				
PERFORMANCE	5.1	Travel speed, laden/unladen	19.8 / 20.4	24.6 / 25.3	18.7 / 19.2	23.2 / 23.9	
	5.1.1	Travel speed, laden/unladen, backwards	19.8 / 20.4		18.7 / 19.2		
	5.2	Lift speed, laden/unladen	m/s				
	5.3	Lowering speed, laden/unladen	m/s				
	5.5	Drawbar pull, laden/unladen ⁽⁶⁾	N	25468/16781	30536/16781	27516/18782	32917/18782
	5.7	Gradeability, laden/unladen ⁽⁷⁾	%	24.3/26.7	29.5/26.7	24/28.3	29.1/28.3
	5.9	Acceleration time, laden/unladen	s	5.3/4.3	5.3/4.5	5.4/4.5	5.5/4.7
	5.10	Service brake	Hydraulic				
	ENGINE	7.1	Engine manufacturer/type	Kubota V3800 E4			
		7.2	Engine power according to ISO 1585	kW			
7.3		Rated speed	min-1				
7.3.1		Torque at 1/min	Nm/min-1				
7.4		Number of cylinders/displacement	cm3				
7.5		Fuel consumption according to VDI cycle	l/h or kg/h				
7.10		Battery voltage/nominal capacity ⁽⁸⁾	V/Ah				
OTHER	8.1	Type of drive unit	Hydrodynamic				
	10.1	Operating pressure for attachments	bar				
	10.2	Oil volume for attachments ⁽⁹⁾	l/min				
	10.3	Hydraulic oil tank, capacity	l				
	10.4	Fuel tank, capacity	l				
	10.7	Sound pressure level at the driver's seat ^{(10) (11)}	dB (A)				
	10.7.1	Sound power level during the workcycle ⁽¹²⁾	dB (A)				
	10.7.2	Guaranteed sound power 2001/14/EC	dB (A)				
	10.8	Towing coupling, type DIN	Pin				

(7) At 4.8km/h. Gradeability figures are provided for comparison of tractive performance, but are not intended to endorse the operation of the vehicle on the stated inclines. Follow instructions in the operating manual regarding operation on inclines

(8) Battery ampere hour (Ah) nominal capacity ratings are estimated

(9) Variable

(10) With and without cab

(11) LPAZ, Measured according to the test cycles and based on the weighting values contained in EN12053

(12) LWAZ, Measured according to the test cycles and based on the weighting values contained in EN12053

All values are nominal values and they are subject to tolerances.

VDI 2198 – GENERAL SPECIFICATIONS – VX SERIES

		Yale					
		GDP 50S VX5	GDP 50 VX6				
GENERAL	1.1	Manufacturer					
	1.2	Model designation					
	1.3	Drive					
	1.3.1	Engine					
	1.3.2	Transmission					
	1.3.3	Brake Type					
	1.4	Operator type					
	1.5	Rated capacity/rated load	Q (t)				
	1.6	Load centre distance	c (mm)	500			
	1.8	Load distance, centre of drive axle to fork	x (mm)	590.6			
1.8.1	Load distance, centre of drive axle to fork (ISS Carriage)	x (mm)	608				
1.9	Wheelbase	y (mm)	2100				
WEIGHT	2.1	Service weight	kg	7027	7520		
	2.2	Axle loading laden, front/rear	kg	10789/1237	11041/1478		
	2.3	Axle loading unladen, front/rear	kg	3192/3835	3206/4314		
TYRES	3.1	Tyres, front/rear	Superelastic				
	3.2	Tyre size, front	300x15				
	3.3	Tyre size, rear	28x9-15				
	3.5	Number of wheels, front/rear (X = driven)	2x / 2				
	3.6	Tread, front	b ₁₀ (mm)	1150			
	3.7	Tread, rear	b ₁₁ (mm)	1162			
	DIMENSIONS	4.1	Tilt of mast/fork carriage forward/backward	α / β (°)			
4.2		Height, mast lowered	h ₁ (mm)	2215			
4.3		Free lift ⁽¹⁾	h ₂ (mm)	100			
4.4		Lift ⁽¹⁾	h ₃ (mm)	2740			
4.5		Height, mast extended ⁽²⁾	h ₄ (mm)	3730			
4.7		Height of overhead guard (cabin)	h ₅ (mm)	2300			
4.8		Seat height/stand height ⁽³⁾	h ₇ (mm)	1321			
4.12		Coupling height	h ₁₀ (mm)	0			
4.19		Overall length	l ₁ (mm)	4500			
4.20		Length to face of forks (Standard Carriage)	l ₂ (mm)	3300			
4.20.1		Length to face of forks (Integrated Side Shift Carriage)	l ₂ (mm)	3317			
4.21		Overall width (single / wide / dual)	b ₁ /b ₂ (mm)	1450 / 1575 / 1875			
4.22		Fork dimensions ISO 2331	s/e/l (mm)	60 / 150 / 1200			
4.23		Fork carriage ISO 2328, class/type A, B		IVA			
4.24		Fork carriage width (Standard Carriage) ⁽⁴⁾	b ₃ (mm)	0			
4.24.1		Fork carriage width (ISS Carriage) ⁽⁴⁾	b ₃ (mm)	1372			
4.31		Ground clearance, laden, below mast	m ₁ (mm)	194			
4.32		Ground clearance, centre of wheelbase	m ₂ (mm)	237			
4.33		Load dimension b ₁₂ × l ₆ crossways	b ₁₂ × l ₆ (mm)	1200 × 1000			
4.34		Aisle width predetermined load dimensions ⁽⁵⁾	Ast (mm)	4668			
4.34.1		Aisle width for pallets 1000 × 1200 crossways ⁽⁵⁾	Ast (mm)	4868			
4.34.2		Aisle width for pallets 800 × 1200 crossways ⁽⁵⁾	Ast (mm)	4868			
4.35		Turning radius	Wa (mm)	2877			
4.36	Internal turning radius	b ₁₃ (mm)	800				
4.36.1	90° intersecting aisle (with pallet W = 1200mm × L = 1000mm)	(mm)	2469				
4.36.2	Step Height (from ground to running board)	(mm)	441				
4.36.3	Step Height (between intermediate steps and floor)	(mm)	360				
PERFORMANCE	5.1	Travel speed, laden/unladen	km/h	18.7 / 19.2	23.2 / 23.9		
	5.1.1	Travel speed, laden/unladen, backwards	km/h	18.7 / 19.2			
	5.2	Lift speed, laden/unladen	m/s	0.45 / 0.46			
	5.3	Lowering speed, laden/unladen	m/s	0.51 / 0.42			
	5.5	Drawbar pull, laden/unladen ⁽⁶⁾	N	27458/18399	32859/18399	27458/18399	32859/18399
	5.7	Gradeability, laden/unladen ⁽⁷⁾	%	23.3/26.5	28.3/26.5	23.3/26.5	28.3/26.5
	5.9	Acceleration time, laden/unladen	s	5.4/4.5	5.5/4.6	5.4/4.5	5.5/4.6
	5.10	Service brake	Hydraulic				
	ENGINE	7.1	Engine manufacturer/type	Kubota V3800 E4			
		7.2	Engine power according to ISO 1585	kW	55		
7.3		Rated speed	min-1	2200			
7.3.1		Torque at 1/min	Nm/min-1	308 / 1400			
7.4		Number of cylinders/displacement	cm3	4 / 3769			
7.5		Fuel consumption according to VDI cycle	l/h or kg/h	5.4	5.8	5.4	5.8
7.10		Battery voltage/nominal capacity ⁽⁸⁾	V/Ah	12 / 105			
OTHER	8.1	Type of drive unit	Hydrodynamic				
	10.1	Operating pressure for attachments	bar	155			
	10.2	Oil volume for attachments ⁽⁹⁾	l/min	83.3			
	10.3	Hydraulic oil tank, capacity	l	67.8			
	10.4	Fuel tank, capacity	l	100.3			
	10.7	Sound pressure level at the driver's seat ^{(10) (11)}	dB (A)	79			
	10.7.1	Sound power level during the workcycle ⁽¹²⁾	dB (A)	99			
	10.7.2	Guaranteed sound power 2001/14/EC	dB (A)	103			
	10.8	Towing coupling, type DIN		Pin			

(1) Top of forks

(2) Add 32mm with load backrest

(3) Full suspension seat in depressed position

(4) Without load backrest, add 32mm with load backrest

(5) Stacking aisle width (lines 4.34 & 4.34.1 & 4.34.2) are based on the V.D.I. standard calculation as shown on illustration. The British Industrial Truck Association recommends the addition of 100 mm to the total clearance (dimension a) for extra operating margin at the rear of the truck

(6) At 1.6 km/h

VDI 2198 – GENERAL SPECIFICATIONS – VX SERIES

GENERAL	1.1	Manufacturer		Yale		
	1.2	Model designation		GDP 55 VX6		
	1.3	Drive		LPG		
	1.3.1	Engine		Kubota 3.8L LPG		
	1.3.2	Transmission		Techtronix 1, 1-Speed	Techtronix 2, 2-Speed	
	1.3.3	Brake Type		Premium Oil Immersed Brakes		
	1.4	Operator type		Seated		
	1.5	Rated capacity/rated load	Q (t)	5.5		
	1.6	Load centre distance	c (mm)	600		
	1.8	Load distance, centre of drive axle to fork	x (mm)	590.6		
1.8.1	Load distance, centre of drive axle to fork (ISS Carriage)	x (mm)	608			
1.9	Wheelbase	y (mm)	2100			
WEIGHT	2.1	Service weight	kg	7811		
	2.2	Axle loading laden, front/rear	kg	11754/1558		
	2.3	Axle loading unladen, front/rear	kg	3134/4677		
TYRES	3.1	Tyres, front/rear		Superelastic		
	3.2	Tyre size, front		300x15		
	3.3	Tyre size, rear		28x9-15		
	3.5	Number of wheels, front/rear (X = driven)		2x / 2		
	3.6	Tread, front	b ₁₀ (mm)	1150		
	3.7	Tread, rear	b ₁₁ (mm)	1162		
	DIMENSIONS	4.1	Tilt of mast/fork carriage forward/backward	α / β (°)	6 / 10	
4.2		Height, mast lowered	h ₁ (mm)	2215		
4.3		Free lift ⁽¹⁾	h ₂ (mm)	100		
4.4		Lift ⁽¹⁾	h ₃ (mm)	2740		
4.5		Height, mast extended ⁽²⁾	h ₄ (mm)	3730		
4.7		Height of overhead guard (cabin)	h ₅ (mm)	2300		
4.8		Seat height/stand height ⁽³⁾	h ₇ (mm)	1321		
4.12		Coupling height	h ₁₀ (mm)	0		
4.19		Overall length	l ₁ (mm)	4541		
4.20		Length to face of forks (Standard Carriage)	l ₂ (mm)	3341		
4.20.1		Length to face of forks (Integrated Side Shift Carriage)	l ₂ (mm)	3358		
4.21		Overall width (single / wide / dual)	b ₁ /b ₂ (mm)	1450 / 1575 / 1875		
4.22		Fork dimensions ISO 2331	s/e/l (mm)	60 / 150 / 1200		
4.23		Fork carriage ISO 2328, class/type A, B		IVA		
4.24		Fork carriage width (Standard Carriage) ⁽⁴⁾	b ₃ (mm)	0		
4.24.1		Fork carriage width (ISS Carriage) ⁽⁴⁾	b ₃ (mm)	1372		
4.31		Ground clearance, laden, below mast	m ₁ (mm)	194		
4.32		Ground clearance, centre of wheelbase	m ₂ (mm)	237		
4.33		Load dimension b ₁₂ × l ₆ crossways	b ₁₂ × l ₆ (mm)	1200 × 1000		
4.34		Aisle width predetermined load dimensions ⁽⁵⁾	Ast (mm)	4706		
4.34.1		Aisle width for pallets 1000 × 1200 crossways ⁽⁵⁾	Ast (mm)	4906		
4.34.2		Aisle width for pallets 800 × 1200 crossways ⁽⁵⁾	Ast (mm)	4906		
4.35		Turning radius	Wa (mm)	2915		
4.36	Internal turning radius	b ₁₃ (mm)	800			
4.36.1	90° intersecting aisle (with pallet W = 1200mm x L = 1000mm)	(mm)	2490			
4.36.2	Step Height (from ground to running board)	(mm)	441			
4.36.3	Step Height (between intermediate steps and floor)	(mm)	360			
PERFORMANCE	5.1	Travel speed, laden/unladen	km/h	18.6 / 19.2	22.9 / 23.9	
	5.1.1	Travel speed, laden/unladen, backwards	km/h	18.6 / 19.2		
	5.2	Lift speed, laden/unladen	m/s	0.45 / 0.46		
	5.3	Lowering speed, laden/unladen	m/s	0.51 / 0.42		
	5.5	Drawbar pull, laden/unladen ⁽⁶⁾	N	27302/17976	32703/17976	
	5.7	Gradeability, laden/unladen ⁽⁷⁾	%	21.7/24.8	26.3/24.8	
	5.9	Acceleration time, laden/unladen	s	5.6/4.5		
	5.10	Service brake		Hydraulic		
	ENGINE	7.1	Engine manufacturer/type		Kubota V3800 E4	
		7.2	Engine power according to ISO 1585	kW	55	
7.3		Rated speed	min-1	2200		
7.3.1		Torque at 1/min	Nm/min-1	308 / 1400		
7.4		Number of cylinders/displacement	cm3	4 / 3769		
7.5		Fuel consumption according to VDI cycle	l/h or kg/h	5.8	6.2	
7.10		Battery voltage/nominal capacity ⁽⁸⁾	V/Ah	12 / 105		
OTHER	8.1	Type of drive unit		Hydrodynamic		
	10.1	Operating pressure for attachments	bar	155		
	10.2	Oil volume for attachments ⁽⁹⁾	l/min	83.3		
	10.3	Hydraulic oil tank, capacity	l	67.8		
	10.4	Fuel tank, capacity	l	100.3		
	10.7	Sound pressure level at the driver's seat ^{(10) (11)}	dB (A)	79		
	10.7.1	Sound power level during the workcycle ⁽¹²⁾	dB (A)	99		
	10.7.2	Guaranteed sound power 2001/14/EC	dB (A)	103		
	10.8	Towing coupling, type DIN		Pin		

(7) At 4.8km/h. Gradeability figures are provided for comparison of tractive performance, but are not intended to endorse the operation of the vehicle on the stated inclines. Follow instructions in the operating manual regarding operation on inclines

(8) Battery ampere hour (Ah) nominal capacity ratings are estimated

(9) Variable

(10) With and without cab

(11) LPAZ, Measured according to the test cycles and based on the weighting values contained in EN12053

(12) LWAZ, Measured according to the test cycles and based on the weighting values contained in EN12053

All values are nominal values and they are subject to tolerances.

VDI 2198 – GENERAL SPECIFICATIONS – VX SERIES

		Yale				
		GDP 40 VX5				
		Diesel				
		Kubota 3.6L DSL				
GENERAL	1.1	Manufacturer				
	1.2	Model designation				
	1.3	Drive				
	1.3.1	Engine				
	1.3.2	Transmission	Electronic Powershift 1, 1-Speed	Electronic Powershift 2, 2-Speed	Techtronix 1, 1-Speed	Techtronix 2, 2-Speed
	1.3.3	Brake Type	Oil Immersed Brakes			
1.4	Operator type	Seated				
1.5	Rated capacity/rated load	Q (t)	4.0			
1.6	Load centre distance	c (mm)	500			
1.8	Load distance, centre of drive axle to fork	x (mm)	522.6			
1.8.1	Load distance, centre of drive axle to fork (ISS Carriage)	x (mm)	555			
1.9	Wheelbase	y (mm)	1830			
WEIGHT	2.1	Service weight	kg			6264
	2.2	Axle loading laden, front/rear	kg			8969/1295
	2.3	Axle loading unladen, front/rear	kg			2733/3531
TYRES	3.1	Tyres, front/rear	Superelastic			
	3.2	Tyre size, front	250x15			
	3.3	Tyre size, rear	7.00x12			
	3.5	Number of wheels, front/rear (X = driven)	2x / 2			
	3.6	Tread, front	b ₁₀ (mm)	1152		
	3.7	Tread, rear	b ₁₁ (mm)	1136		
	DIMENSIONS	4.1	Tilt of mast/fork carriage forward/backward	α / β (°)		6 / 10
4.2		Height, mast lowered	h ₁ (mm)		2171	
4.3		Free lift ⁽¹⁾	h ₂ (mm)		100	
4.4		Lift ⁽¹⁾	h ₃ (mm)		3000	
4.5		Height, mast extended ⁽²⁾	h ₄ (mm)		3815	
4.7		Height of overhead guard (cabin)	h ₆ (mm)		2258	
4.8		Seat height/stand height ⁽³⁾	h ₇ (mm)		1279	
4.12		Coupling height	h ₁₀ (mm)	429	0	
4.19		Overall length	l ₁ (mm)		3946	
4.20		Length to face of forks (Standard Carriage)	l ₂ (mm)		2946	
4.20.1		Length to face of forks (Integrated Side Shift Carriage)	l ₂ (mm)		2978	
4.21		Overall width (single / wide / dual)	b ₁ /b ₂ (mm)		1402 / 1485 / 1773	
4.22		Fork dimensions ISO 2331	s/e/l (mm)		50 / 120 / 1000	
4.23		Fork carriage ISO 2328, class/type A, B	IIIa			
4.24		Fork carriage width (Standard Carriage) ⁽⁴⁾	b ₃ (mm)	1219	0	
4.24.1		Fork carriage width (ISS Carriage) ⁽⁴⁾	b ₃ (mm)		1219	
4.31		Ground clearance, laden, below mast	m ₁ (mm)		151	
4.32		Ground clearance, centre of wheelbase	m ₂ (mm)		194	
4.33		Load dimension b ₁₂ × l ₆ crossways	b ₁₂ × l ₆ (mm)			1200 x 1000
4.34		Aisle width predetermined load dimensions ⁽⁵⁾	Ast (mm)		4293	
4.34.1		Aisle width for pallets 1000 × 1200 crossways ⁽⁵⁾	Ast (mm)		4493	
4.34.2		Aisle width for pallets 800 × 1200 crossways ⁽⁵⁾	Ast (mm)		4493	
4.35		Turning radius	Wa (mm)		2570	
4.36	Internal turning radius	b ₁₃ (mm)		751		
4.36.1	90° intersecting aisle (with pallet W = 1200mm x L = 1000mm)	(mm)		2298		
4.36.2	Step Height (from ground to running board)	(mm)		441		
4.36.3	Step Height (between intermediate steps and floor)	(mm)		360		
PERFORMANCE	5.1	Travel speed, laden/unladen	17.9 / 18.8	20.5 / 22.9	17.9 / 18.8	20.5 / 22.9
	5.1.1	Travel speed, laden/unladen, backwards	17.9 / 18.8			
	5.2	Lift speed, laden/unladen	0.53 / 0.60			
	5.3	Lowering speed, laden/unladen	0.55 / 0.47			
	5.5	Drawbar pull, laden/unladen ⁽⁶⁾	25973/15616	31095/15616	25973/15616	31095/15616
	5.7	Gradeability, laden/unladen ⁽⁷⁾	27.3/27.2	33.2/27.2	27.3/27.2	33.2/27.2
	5.9	Acceleration time, laden/unladen	5.8/4.8	5.9/5	5.8/4.8	5.9/5
	5.10	Service brake	Hydraulic			
	ENGINE	7.1	Engine manufacturer/type	Kubota V3600 IDI-T		
		7.2	Engine power according to ISO 1585	kW		
7.3		Rated speed	min-1			2400
7.3.1		Torque at 1/min	Nm/min-1			296 / 1600
7.4		Number of cylinders/displacement	cm3			4 / 3620
7.5		Fuel consumption according to VDI cycle	5.7	5.9	5.7	5.9
7.10		Battery voltage/nominal capacity ⁽⁸⁾	V/Ah			12 / 105
OTHER	8.1	Type of drive unit	Hydrodynamic			
	10.1	Operating pressure for attachments	bar			155
	10.2	Oil volume for attachments ⁽⁹⁾	l/min			83.3
	10.3	Hydraulic oil tank, capacity	l			51
	10.4	Fuel tank, capacity	l			79
	10.7	Sound pressure level at the driver's seat ^{(10) (11)}	dB (A)			81
	10.7.1	Sound power level during the workcycle ⁽¹²⁾	dB (A)			101
	10.7.2	Guaranteed sound power 2001/14/EC	dB (A)			105
	10.8	Towing coupling, type DIN	Pin			

(1) Top of forks

(2) Add 32mm with load backrest

(3) Full suspension seat in depressed position

(4) Without load backrest, add 32mm with load backrest

(5) Stacking aisle width (lines 4.34 & 4.34.1 & 4.34.2) are based on the VDI standard calculation as shown on illustration. The British Industrial Truck Association recommends the addition of 100 mm to the total clearance (dimension a) for extra operating margin at the rear of the truck

(6) At 1.6 km/h

VDI 2198 – GENERAL SPECIFICATIONS – VX SERIES

GENERAL	1.1	Manufacturer	Yale				
	1.2	Model designation	GDP 40 VX6				
	1.3	Drive	Diesel				
	1.3.1	Engine	Kubota 3.6L DSL				
	1.3.2	Transmission	Electronic Powershift 1, 1-Speed	Techtronix 2, 2-Speed	Techtronix 1, 1-Speed	Techtronix 2, 2-Speed	
	1.3.3	Brake Type	Oil Immersed Brakes				
	1.4	Operator type	Seated				
	1.5	Rated capacity/rated load	Q (t)	4.0			
	1.6	Load centre distance	c (mm)	600			
	1.8	Load distance, centre of drive axle to fork	x (mm)	522.6			
1.8.1	Load distance, centre of drive axle to fork (ISS Carriage)	x (mm)	555				
1.9	Wheelbase	y (mm)	1830				
WEIGHT	2.1	Service weight	kg				
	2.2	Axle loading laden, front/rear	6470				
	2.3	Axle loading unladen, front/rear	9133/1337				
TYRES	3.1	Tyres, front/rear	kg				
	3.2	Tyre size, front	2678/3792				
	3.3	Tyre size, rear	Superelastic				
	3.5	Number of wheels, front/rear (X = driven)	250x15				
	3.6	Tread, front	7.00x12				
	3.7	Tread, rear	2x / 2				
	DIMENSIONS	4.1	Tilt of mast/fork carriage forward/backward	b ₁₀ (mm)			
4.2		Height, mast lowered	1152				
4.3		Free lift ⁽¹⁾	b ₁₁ (mm)				
4.4		Lift ⁽¹⁾	1136				
4.5		Height, mast extended ⁽²⁾	α / β (°)				
4.7		Height of overhead guard (cabin)	6 / 10				
4.8		Seat height/stand height ⁽³⁾	h ₁ (mm)				
4.12		Coupling height	2171				
4.19		Overall length	h ₂ (mm)				
4.20		Length to face of forks (Standard Carriage)	100				
4.20.1		Length to face of forks (Integrated Side Shift Carriage)	h ₃ (mm)				
4.21		Overall width (single / wide / dual)	3000				
4.22		Fork dimensions ISO 2331	h ₄ (mm)				
4.23		Fork carriage ISO 2328, class/type A, B	3815				
4.24		Fork carriage width (Standard Carriage) ⁽⁴⁾	h ₆ (mm)				
4.24.1		Fork carriage width (ISS Carriage) ⁽⁴⁾	2258				
4.31		Ground clearance, laden, below mast	h ₇ (mm)				
4.32		Ground clearance, centre of wheelbase	1279				
4.33		Load dimension b ₁₂ × l ₆ crossways	h ₁₀ (mm)				
4.34		Aisle width predetermined load dimensions ⁽⁵⁾	0				
4.34.1		Aisle width for pallets 1000 × 1200 crossways ⁽⁵⁾	l ₁ (mm)				
4.34.2	Aisle width for pallets 800 × 1200 crossways ⁽⁵⁾	3977					
4.35	Turning radius	l ₂ (mm)					
4.36	Internal turning radius	2977					
4.36.1	90° intersecting aisle (with pallet W = 1200mm x L = 1000mm)	l ₂ (mm)					
4.36.2	Step Height (from ground to running board)	3009					
4.36.3	Step Height (between intermediate steps and floor)	b ₁ /b ₂ (mm)					
PERFORMANCE	5.1	Travel speed, laden/unladen	1402 / 1485 / 1773				
	5.1.1	Travel speed, laden/unladen, backwards	50 / 120 / 1200				
	5.2	Lift speed, laden/unladen	s/e/l (mm)				
	5.3	Lowering speed, laden/unladen	11A				
	5.5	Drawbar pull, laden/unladen ⁽⁶⁾	b ₃ (mm)				
	5.7	Gradeability, laden/unladen ⁽⁷⁾	0				
	5.9	Acceleration time, laden/unladen	b ₃ (mm)				
	5.10	Service brake	m ₁ (mm)				
	ENGINE	7.1	Engine manufacturer/type	m ₂ (mm)			
		7.2	Engine power according to ISO 1585	m ₂ (mm)			
7.3		Rated speed	194				
7.3.1		Torque at 1/min	1200 x 1000				
7.4		Number of cylinders/displacement	Ast (mm)				
7.5		Fuel consumption according to VDI cycle	4322				
7.10		Battery voltage/nominal capacity ⁽⁸⁾	4522				
OTHER		8.1	Type of drive unit	Ast (mm)			
		10.1	Operating pressure for attachments	4522			
		10.2	Oil volume for attachments ⁽⁹⁾	4522			
	10.3	Hydraulic oil tank, capacity	4522				
	10.4	Fuel tank, capacity	2599				
	10.7	Sound pressure level at the driver's seat ^{(10) (11)}	751				
	10.7.1	Sound power level during the workcycle ⁽¹²⁾	2314				
	10.7.2	Guaranteed sound power 2001/14/EC	441				
	10.8	Towing coupling, type DIN	360				

(7) At 4.8km/h. Gradeability figures are provided for comparison of tractive performance, but are not intended to endorse the operation of the vehicle on the stated inclines. Follow instructions in the operating manual regarding operation on inclines

(8) Battery ampere hour (Ah) nominal capacity ratings are estimated

(9) Variable

(10) With and without cab

(11) LPAZ, Measured according to the test cycles and based on the weighting values contained in EN12053

(12) LWAZ, Measured according to the test cycles and based on the weighting values contained in EN12053

All values are nominal values and they are subject to tolerances.

VDI 2198 – GENERAL SPECIFICATIONS – VX SERIES

GENERAL					
1.1	Manufacturer	Yale			
1.2	Model designation	GDP 455 VX5			
1.3	Drive	Diesel			
1.3.1	Engine	Kubota 3.6L DSL			
1.3.2	Transmission	Electronic Powershift 1, 1-Speed	Electronic Powershift 2, 2-Speed	Techtronix 1, 1-Speed	Techtronix 2, 2-Speed
1.3.3	Brake Type	Oil Immersed Brakes			
1.4	Operator type	Seated			
1.5	Rated capacity/rated load	Q (t)	4.5		
1.6	Load centre distance	c (mm)	500		
1.8	Load distance, centre of drive axle to fork	x (mm)	590.6		
1.8.1	Load distance, centre of drive axle to fork (ISS Carriage)	x (mm)	608		
1.9	Wheelbase	y (mm)	1830		
WEIGHT					
2.1	Service weight	kg	6826		
2.2	Axle loading laden, front/rear	kg	10114/1212		
2.3	Axle loading unladen, front/rear	kg	2931/3895		
TYRES					
3.1	Tyres, front/rear	Superelastic			
3.2	Tyre size, front	250x15			
3.3	Tyre size, rear	7.00x12			
3.5	Number of wheels, front/rear (X = driven)	2x / 2			
3.6	Tread, front	b ₁₀ (mm)	1152		
3.7	Tread, rear	b ₁₁ (mm)	1136		
DIMENSIONS					
4.1	Tilt of mast/fork carriage forward/backward	α / β (°)	6 / 10		
4.2	Height, mast lowered	h ₁ (mm)	2215		
4.3	Free lift ⁽¹⁾	h ₂ (mm)	100		
4.4	Lift ⁽¹⁾	h ₃ (mm)	2740		
4.5	Height, mast extended ⁽²⁾	h ₄ (mm)	3730		
4.7	Height of overhead guard (cabin)	h ₆ (mm)	2258		
4.8	Seat height/stand height ⁽³⁾	h ₇ (mm)	1279		
4.12	Coupling height	h ₁₀ (mm)	0		
4.19	Overall length	l ₁ (mm)	4266		
4.20	Length to face of forks (Standard Carriage)	l ₂ (mm)	3066		
4.20.1	Length to face of forks (Integrated Side Shift Carriage)	l ₂ (mm)	3083		
4.21	Overall width (single / wide / dual)	b ₁ /b ₂ (mm)	1402 / 1485 / 1773		
4.22	Fork dimensions ISO 2331	s/e/l (mm)	60 / 150 / 1200		
4.23	Fork carriage ISO 2328, class/type A, B	IVA			
4.24	Fork carriage width (Standard Carriage) ⁽⁴⁾	b ₃ (mm)	0		
4.24.1	Fork carriage width (ISS Carriage) ⁽⁴⁾	b ₃ (mm)	1219		
4.31	Ground clearance, laden, below mast	m ₁ (mm)	151		
4.32	Ground clearance, centre of wheelbase	m ₂ (mm)	194		
4.33	Load dimension b ₁₂ × l ₆ crossways	b ₁₂ × l ₆ (mm)	1200 × 1000		
4.34	Aisle width predetermined load dimensions ⁽⁵⁾	Ast (mm)	4342		
4.34.1	Aisle width for pallets 1000 × 1200 crossways ⁽⁵⁾	Ast (mm)	4542		
4.34.2	Aisle width for pallets 800 × 1200 crossways ⁽⁵⁾	Ast (mm)	4542		
4.35	Turning radius	W _a (mm)	2619		
4.36	Internal turning radius	b ₁₃ (mm)	751		
4.36.1	90° intersecting aisle (with pallet W = 1200mm × L = 1000mm)	(mm)	2332		
4.36.2	Step Height (from ground to running board)	(mm)	441		
4.36.3	Step Height (between intermediate steps and floor)	(mm)	360		
PERFORMANCE					
5.1	Travel speed, laden/unladen	km/h	17.6 / 18.7	19.8 / 22.7	17.6 / 18.7
5.1.1	Travel speed, laden/unladen, backwards	km/h	17.6 / 18.7		
5.2	Lift speed, laden/unladen	m/s	0.45 / 0.49		
5.3	Lowering speed, laden/unladen	m/s	0.51 / 0.42		
5.5	Drawbar pull, laden/unladen ⁽⁶⁾	N	25765/16781	30887/16781	25765/16781
5.7	Gradeability, laden/unladen ⁽⁷⁾	%	24.6/26.7	29.9/26.7	24.6/26.7
5.9	Acceleration time, laden/unladen	s	6.1/5	6.1/5.1	6.1/5
5.10	Service brake	Hydraulic			
ENGINE					
7.1	Engine manufacturer/type	Kubota V3600 IDI-T			
7.2	Engine power according to ISO 1585	kW	57		
7.3	Rated speed	min-1	2400		
7.3.1	Torque at 1/min	Nm/min-1	296 / 1600		
7.4	Number of cylinders/displacement	cm3	4 / 3620		
7.5	Fuel consumption according to VDI cycle	l/h or kg/h	6.1	6.4	6.1
7.10	Battery voltage/nominal capacity ⁽⁸⁾	V/Ah	12 / 105		
OTHER					
8.1	Type of drive unit	Hydrodynamic			
10.1	Operating pressure for attachments	bar	155		
10.2	Oil volume for attachments ⁽⁹⁾	l/min	83.3		
10.3	Hydraulic oil tank, capacity	l	51		
10.4	Fuel tank, capacity	l	79		
10.7	Sound pressure level at the driver's seat ^{(10) (11)}	dB (A)	81		
10.7.1	Sound power level during the workcycle ⁽¹²⁾	dB (A)	101		
10.7.2	Guaranteed sound power 2001/14/EC	dB (A)	105		
10.8	Towing coupling, type DIN	Pin			

(1) Top of forks

(2) Add 32mm with load backrest

(3) Full suspension seat in depressed position

(4) Without load backrest, add 32mm with load backrest

(5) Stacking aisle width (lines 4.34 & 4.34.1 & 4.34.2) are based on the VDI standard calculation as shown on illustration. The British Industrial Truck Association recommends the addition of 100 mm to the total clearance (dimension a) for extra operating margin at the rear of the truck

(6) At 1.6 km/h

VDI 2198 – GENERAL SPECIFICATIONS – VX SERIES

		Yale					
GENERAL	1.1	Manufacturer	GDP 455 VX6				
	1.2	Model designation	Diesel				
	1.3	Drive	Kubota 3.6L DSL				
	1.3.1	Engine	Kubota 3.6L DSL				
	1.3.2	Transmission	Electronic Powershift 1, 1-Speed	Electronic Powershift 2, 2-Speed	Techtronix 1, 1-Speed	Techtronix 2, 2-Speed	
	1.3.3	Brake Type	Oil Immersed Brakes				
	1.4	Operator type	Seated				
	1.5	Rated capacity/rated load	Q (t)	4.5			
	1.6	Load centre distance	c (mm)	600			
	1.8	Load distance, centre of drive axle to fork	x (mm)	590.6			
1.8.1	Load distance, centre of drive axle to fork (ISS Carriage)	x (mm)	608				
1.9	Wheelbase	y (mm)	2100				
WEIGHT	2.1	Service weight	kg				
	2.2	Axle loading laden, front/rear	kg				
	2.3	Axle loading unladen, front/rear	kg				
TYRES	3.1	Tyres, front/rear	Superelastic				
	3.2	Tyre size, front	300x15				
	3.3	Tyre size, rear	28x9-15				
	3.5	Number of wheels, front/rear (X = driven)	2x / 2				
	3.6	Tread, front	b ₁₀ (mm)	1150			
	3.7	Tread, rear	b ₁₁ (mm)	1162			
	DIMENSIONS	4.1	Tilt of mast/fork carriage forward/backward	α / β (°)	6 / 10		
4.2		Height, mast lowered	h ₁ (mm)	2215			
4.3		Free lift ⁽¹⁾	h ₂ (mm)	100			
4.4		Lift ⁽¹⁾	h ₃ (mm)	2740			
4.5		Height, mast extended ⁽²⁾	h ₄ (mm)	3730			
4.7		Height of overhead guard (cabin)	h ₆ (mm)	2300			
4.8		Seat height/stand height ⁽³⁾	h ₇ (mm)	1321			
4.12		Coupling height	h ₁₀ (mm)	0			
4.19		Overall length	l ₁ (mm)	4457			
4.20		Length to face of forks (Standard Carriage)	l ₂ (mm)	3257			
4.20.1		Length to face of forks (Integrated Side Shift Carriage)	l ₂ (mm)	3274			
4.21		Overall width (single / wide / dual)	b ₁ /b ₂ (mm)	1450 / 1575 / 1875			
4.22		Fork dimensions ISO 2331	s/e/l (mm)	60 / 150 / 1200			
4.23		Fork carriage ISO 2328, class/type A, B		IVA			
4.24		Fork carriage width (Standard Carriage) ⁽⁴⁾	b ₃ (mm)	0			
4.24.1		Fork carriage width (ISS Carriage) ⁽⁴⁾	b ₃ (mm)	1372			
4.31		Ground clearance, laden, below mast	m ₁ (mm)	194			
4.32		Ground clearance, centre of wheelbase	m ₂ (mm)	237			
4.33		Load dimension b ₁₂ × l ₆ crossways	b ₁₂ × l ₆ (mm)	1200 × 1000			
4.34		Aisle width predetermined load dimensions ⁽⁵⁾	Ast (mm)	4628			
4.34.1		Aisle width for pallets 1000 × 1200 crossways ⁽⁵⁾	Ast (mm)	4828			
4.34.2		Aisle width for pallets 800 × 1200 crossways ⁽⁵⁾	Ast (mm)	4828			
4.35		Turning radius	W _a (mm)	2837			
4.36	Internal turning radius	b ₁₃ (mm)	800				
4.36.1	90° intersecting aisle (with pallet W = 1200mm × L = 1000mm)	(mm)	2447				
4.36.2	Step Height (from ground to running board)	(mm)	441				
4.36.3	Step Height (between intermediate steps and floor)	(mm)	360				
PERFORMANCE	5.1	Travel speed, laden/unladen	km/h	16.6 / 17.6	18.7 / 21.2	16.6 / 17.6	18.7 / 21.2
	5.1.1	Travel speed, laden/unladen, backwards	km/h	16.6 / 17.6			
	5.2	Lift speed, laden/unladen	m/s	0.45 / 0.49			
	5.3	Lowering speed, laden/unladen	m/s	0.51 / 0.42			
	5.5	Drawbar pull, laden/unladen ⁽⁶⁾	N	27834/18782	33291/18782	27834/18782	33291/18782
	5.7	Gradeability, laden/unladen ⁽⁷⁾	%	24.3/28.3	29.4/28.3	24.3/28.3	29.4/28.3
	5.9	Acceleration time, laden/unladen	s	6.3/5.2	6.3/5.3	6.3/5.2	6.3/5.3
	5.10	Service brake		Hydraulic			
	ENGINE	7.1	Engine manufacturer/type	Kubota V3600 IDI-T			
		7.2	Engine power according to ISO 1585	kW	57		
7.3		Rated speed	min-1	2400			
7.3.1		Torque at 1/min	Nm/min-1	296 / 1600			
7.4		Number of cylinders/displacement	cm3	4 / 3620			
7.5		Fuel consumption according to VDI cycle	l/h or kg/h	6.4	6.8	6.4	6.8
7.10		Battery voltage/nominal capacity ⁽⁸⁾	V/Ah	12 / 105			
OTHER	8.1	Type of drive unit	Hydrodynamic				
	10.1	Operating pressure for attachments	bar	155			
	10.2	Oil volume for attachments ⁽⁹⁾	l/min	83.3			
	10.3	Hydraulic oil tank, capacity	l	67.8			
	10.4	Fuel tank, capacity	l	100.3			
	10.7	Sound pressure level at the driver's seat ^{(10) (11)}	dB (A)	81			
	10.7.1	Sound power level during the workcycle ⁽¹²⁾	dB (A)	101			
	10.7.2	Guaranteed sound power 2001/14/EC	dB (A)	105			
	10.8	Towing coupling, type DIN		Pin			

(7) At 4.8km/h. Gradeability figures are provided for comparison of tractive performance, but are not intended to endorse the operation of the vehicle on the stated inclines. Follow instructions in the operating manual regarding operation on inclines

(8) Battery ampere hour (Ah) nominal capacity ratings are estimated

(9) Variable

(10) With and without cab

(11) LPAZ, Measured according to the test cycles and based on the weighting values contained in EN12053

(12) LWAZ, Measured according to the test cycles and based on the weighting values contained in EN12053

All values are nominal values and they are subject to tolerances.

VDI 2198 – GENERAL SPECIFICATIONS – VX SERIES

		Yale					
		GDP 50S VX5					
		Diesel					
		Kubota 3.6L DSL					
GENERAL	1.1	Manufacturer					
	1.2	Model designation					
	1.3	Drive					
	1.3.1	Engine					
	1.3.2	Transmission	Electronic Powershift 1, 1-Speed	Electronic Powershift 2, 2-Speed	Techtronix 1, 1-Speed	Techtronix 2, 2-Speed	
	1.3.3	Brake Type	Oil Immersed Brakes				
	1.4	Operator type	Seated				
	1.5	Rated capacity/rated load	Q (t)	5.0			
	1.6	Load centre distance	c (mm)	500			
	1.8	Load distance, centre of drive axle to fork	x (mm)	590.6			
1.8.1	Load distance, centre of drive axle to fork (ISS Carriage)	x (mm)	608				
1.9	Wheelbase	y (mm)	2100				
WEIGHT	2.1	Service weight	kg				
	2.2	Axle loading laden, front/rear	kg				
	2.3	Axle loading unladen, front/rear	kg				
TYRES	3.1	Tyres, front/rear	Superelastic				
	3.2	Tyre size, front	300x15				
	3.3	Tyre size, rear	28x9-15				
	3.5	Number of wheels, front/rear (X = driven)	2x / 2				
	3.6	Tread, front	b ₁₀ (mm)	1150			
	3.7	Tread, rear	b ₁₁ (mm)	1162			
	DIMENSIONS	4.1	Tilt of mast/fork carriage forward/backward	α / β (°)	6 / 10		
4.2		Height, mast lowered	h ₁ (mm)	2215			
4.3		Free lift ⁽¹⁾	h ₂ (mm)	100			
4.4		Lift ⁽¹⁾	h ₃ (mm)	2740			
4.5		Height, mast extended ⁽²⁾	h ₄ (mm)	3730			
4.7		Height of overhead guard (cabin)	h ₆ (mm)	2300			
4.8		Seat height/stand height ⁽³⁾	h ₇ (mm)	1321			
4.12		Coupling height	h ₁₀ (mm)	0			
4.19		Overall length	l ₁ (mm)	4500			
4.20		Length to face of forks (Standard Carriage)	l ₂ (mm)	3300			
4.20.1		Length to face of forks (Integrated Side Shift Carriage)	l ₂ (mm)	3317			
4.21		Overall width (single / wide / dual)	b ₁ /b ₂ (mm)	1450 / 1575 / 1875			
4.22		Fork dimensions ISO 2331	s/e/l (mm)	60 / 150 / 1200			
4.23		Fork carriage ISO 2328, class/type A, B		IVA			
4.24		Fork carriage width (Standard Carriage) ⁽⁴⁾	b ₃ (mm)	0			
4.24.1		Fork carriage width (ISS Carriage) ⁽⁴⁾	b ₃ (mm)	1372			
4.31		Ground clearance, laden, below mast	m ₁ (mm)	194			
4.32		Ground clearance, centre of wheelbase	m ₂ (mm)	237			
4.33		Load dimension b ₁₂ × l ₆ crossways	b ₁₂ × l ₆ (mm)	1200 × 1000			
4.34		Aisle width predetermined load dimensions ⁽⁵⁾	Ast (mm)	4668			
4.34.1		Aisle width for pallets 1000 × 1200 crossways ⁽⁵⁾	Ast (mm)	4868			
4.34.2		Aisle width for pallets 800 × 1200 crossways ⁽⁵⁾	Ast (mm)	4868			
4.35		Turning radius	Wa (mm)	2877			
4.36	Internal turning radius	b ₁₃ (mm)	800				
4.36.1	90° intersecting aisle (with pallet W = 1200mm × L = 1000mm)	(mm)	2469				
4.36.2	Step Height (from ground to running board)	(mm)	441				
4.36.3	Step Height (between intermediate steps and floor)	(mm)	360				
PERFORMANCE	5.1	Travel speed, laden/unladen	km/h	16.5 / 17.6	18.5 / 21.3	16.5 / 17.6	18.5 / 21.3
	5.1.1	Travel speed, laden/unladen, backwards	km/h	16.5 / 17.6			
	5.2	Lift speed, laden/unladen	m/s	0.45 / 0.49			
	5.3	Lowering speed, laden/unladen	m/s	0.51 / 0.42			
	5.5	Drawbar pull, laden/unladen ⁽⁶⁾	N	27776/18399	33233/18399	27776/18399	33233/18399
	5.7	Gradeability, laden/unladen ⁽⁷⁾	%	23.6/26.5	28.6/26.5	23.6/26.5	28.6/26.5
	5.9	Acceleration time, laden/unladen	s	6.3/5.2	6.3/5.3	6.3/5.2	6.3/5.3
	5.10	Service brake		Hydraulic			
	ENGINE	7.1	Engine manufacturer/type	Kubota V3600 IDI-T			
		7.2	Engine power according to ISO 1585	kW	57		
7.3		Rated speed	min-1	2400			
7.3.1		Torque at 1/min	Nm/min-1	296 / 1600			
7.4		Number of cylinders/displacement	cm3	4 / 3620			
7.5		Fuel consumption according to VDI cycle	l/h or kg/h	6.8	7.2	6.8	7.2
7.10		Battery voltage/nominal capacity ⁽⁸⁾	V/Ah	12 / 105			
OTHER	8.1	Type of drive unit	Hydrodynamic				
	10.1	Operating pressure for attachments	bar	155			
	10.2	Oil volume for attachments ⁽⁹⁾	l/min	83.3			
	10.3	Hydraulic oil tank, capacity	l	67.8			
	10.4	Fuel tank, capacity	l	100.3			
	10.7	Sound pressure level at the driver's seat ^{(10) (11)}	dB (A)	81			
	10.7.1	Sound power level during the workcycle ⁽¹²⁾	dB (A)	101			
	10.7.2	Guaranteed sound power 2001/14/EC	dB (A)	105			
	10.8	Towing coupling, type DIN		Pin			

(1) Top of forks

(2) Add 32mm with load backrest

(3) Full suspension seat in depressed position

(4) Without load backrest, add 32mm with load backrest

(5) Stacking aisle width (lines 4.34 & 4.34.1 & 4.34.2) are based on the VDI standard calculation as shown on illustration. The British Industrial Truck Association recommends the addition of 100 mm to the total clearance (dimension a) for extra operating margin at the rear of the truck

(6) At 1.6 km/h

VDI 2198 – GENERAL SPECIFICATIONS – VX SERIES

GENERAL						
1.1	Manufacturer	Yale				
1.2	Model designation	GDP 50 VX6				
1.3	Drive	Diesel				
1.3.1	Engine	Kubota 3.6L DSL				
1.3.2	Transmission	Electronic Powershift 1, 1-Speed	Electronic Powershift 2, 2-Speed	Techtronix 1, 1-Speed	Techtronix 2, 2-Speed	
1.3.3	Brake Type	Oil Immersed Brakes				
1.4	Operator type	Seated				
1.5	Rated capacity/rated load	Q (t)	5.0			
1.6	Load centre distance	c (mm)	600			
1.8	Load distance, centre of drive axle to fork	x (mm)	590.6			
1.8.1	Load distance, centre of drive axle to fork (ISS Carriage)	x (mm)	608			
1.9	Wheelbase	y (mm)	2100			
WEIGHT						
2.1	Service weight	kg	7520			
2.2	Axle loading laden, front/rear	kg	11041/1478			
2.3	Axle loading unladen, front/rear	kg	3206/4314			
TYRES						
3.1	Tyres, front/rear	Superelastic				
3.2	Tyre size, front	300x15				
3.3	Tyre size, rear	28x9-15				
3.5	Number of wheels, front/rear (X = driven)	2x / 2				
3.6	Tread, front	b ₁₀ (mm)	1150			
3.7	Tread, rear	b ₁₁ (mm)	1162			
DIMENSIONS						
4.1	Tilt of mast/fork carriage forward/backward	α / β (°)	6 / 10			
4.2	Height, mast lowered	h ₁ (mm)	2215			
4.3	Free lift ⁽¹⁾	h ₂ (mm)	100			
4.4	Lift ⁽¹⁾	h ₃ (mm)	2740			
4.5	Height, mast extended ⁽²⁾	h ₄ (mm)	3730			
4.7	Height of overhead guard (cabin)	h ₆ (mm)	2300			
4.8	Seat height/stand height ⁽³⁾	h ₇ (mm)	1321			
4.12	Coupling height	h ₁₀ (mm)	0			
4.19	Overall length	l ₁ (mm)	4500			
4.20	Length to face of forks (Standard Carriage)	l ₂ (mm)	3300			
4.20.1	Length to face of forks (Integrated Side Shift Carriage)	l ₂ (mm)	3317			
4.21	Overall width (single / wide / dual)	b ₁ /b ₂ (mm)	1450 / 1575 / 1875			
4.22	Fork dimensions ISO 2331	s/e/l (mm)	60 / 150 / 1200			
4.23	Fork carriage ISO 2328, class/type A, B		IVA			
4.24	Fork carriage width (Standard Carriage) ⁽⁴⁾	b ₃ (mm)	0			
4.24.1	Fork carriage width (ISS Carriage) ⁽⁴⁾	b ₃ (mm)	1372			
4.31	Ground clearance, laden, below mast	m ₁ (mm)	194			
4.32	Ground clearance, centre of wheelbase	m ₂ (mm)	237			
4.33	Load dimension b ₁₂ × l ₆ crossways	b ₁₂ × l ₆ (mm)	1200 × 1000			
4.34	Aisle width predetermined load dimensions ⁽⁵⁾	Ast (mm)	4668			
4.34.1	Aisle width for pallets 1000 × 1200 crossways ⁽⁵⁾	Ast (mm)	4868			
4.34.2	Aisle width for pallets 800 × 1200 crossways ⁽⁵⁾	Ast (mm)	4868			
4.35	Turning radius	Wa (mm)	2877			
4.36	Internal turning radius	b ₁₃ (mm)	800			
4.36.1	90° intersecting aisle (with pallet W = 1200mm × L = 1000mm)	(mm)	2469			
4.36.2	Step Height (from ground to running board)	(mm)	441			
4.36.3	Step Height (between intermediate steps and floor)	(mm)	360			
PERFORMANCE						
5.1	Travel speed, laden/unladen	km/h	16.5 / 17.6	18.5 / 21.3	16.5 / 17.6	18.5 / 21.3
5.1.1	Travel speed, laden/unladen, backwards	km/h	16.5 / 17.6			
5.2	Lift speed, laden/unladen	m/s	0.45 / 0.49			
5.3	Lowering speed, laden/unladen	m/s	0.51 / 0.42			
5.5	Drawbar pull, laden/unladen ⁽⁶⁾	N	27776/18399	33233/18399	27776/18399	33233/18399
5.7	Gradeability, laden/unladen ⁽⁷⁾	%	23.6/26.5	28.6/26.5	23.6/26.5	28.6/26.5
5.9	Acceleration time, laden/unladen	s	6.3/5.2	6.3/5.3	6.3/5.2	6.3/5.3
5.10	Service brake		Hydraulic			
ENGINE						
7.1	Engine manufacturer/type	Kubota V3600 IDI-T				
7.2	Engine power according to ISO 1585	kW	57			
7.3	Rated speed	min-1	2400			
7.3.1	Torque at 1/min	Nm/min-1	296 / 1600			
7.4	Number of cylinders/displacement	cm3	4 / 3620			
7.5	Fuel consumption according to VDI cycle	l/h or kg/h	6.8	7.2	6.8	7.2
7.10	Battery voltage/nominal capacity ⁽⁸⁾	V/Ah	12 / 105			
OTHER						
8.1	Type of drive unit	Hydrodynamic				
10.1	Operating pressure for attachments	bar	155			
10.2	Oil volume for attachments ⁽⁹⁾	l/min	83.3			
10.3	Hydraulic oil tank, capacity	l	67.8			
10.4	Fuel tank, capacity	l	100.3			
10.7	Sound pressure level at the driver's seat ^{(10) (11)}	dB (A)	81			
10.7.1	Sound power level during the workcycle ⁽¹²⁾	dB (A)	101			
10.7.2	Guaranteed sound power 2001/14/EC	dB (A)	105			
10.8	Towing coupling, type DIN		Pin			

(7) At 4.8km/h. Gradeability figures are provided for comparison of tractive performance, but are not intended to endorse the operation of the vehicle on the stated inclines. Follow instructions in the operating manual regarding operation on inclines

(8) Battery ampere hour (Ah) nominal capacity ratings are estimated

(9) Variable

(10) With and without cab

(11) LPAZ, Measured according to the test cycles and based on the weighting values contained in EN12053

(12) LWAZ, Measured according to the test cycles and based on the weighting values contained in EN12053

All values are nominal values and they are subject to tolerances.

VDI 2198 – GENERAL SPECIFICATIONS – VX SERIES

			Yale GDP 55 VX6				
GENERAL	1.1	Manufacturer	Diesel				
	1.2	Model designation	Kubota 3.6L DSL				
	1.3	Drive	Electronic Powershift 1, 1-Speed				
	1.3.1	Engine	Electronic Powershift 2, 2-Speed				
	1.3.2	Transmission	Techtronix 1, 1-Speed				
	1.3.3	Brake Type	Techtronix 2, 2-Speed				
	1.4	Operator type	Oil Immersed Brakes				
	1.5	Rated capacity/rated load	Seated				
	1.6	Load centre distance	Q (t)	5.5			
	1.8	Load distance, centre of drive axle to fork	c (mm)	600			
WEIGHT	1.8.1	Load distance, centre of drive axle to fork (ISS Carriage)	x (mm)	590.6			
	1.9	Wheelbase	y (mm)	608			
	2.1	Service weight	kg	2100			
	2.2	Axle loading laden, front/rear	kg	7811			
	2.3	Axle loading unladen, front/rear	kg	11754/1558			
	TYRES	3.1	Tyres, front/rear	3134/4677			
		3.2	Tyre size, front	Superelastic			
		3.3	Tyre size, rear	300x15			
		3.5	Number of wheels, front/rear (X = driven)	28x9-15			
		3.6	Tread, front	b ₁₀ (mm)	2x / 2		
3.7		Tread, rear	b ₁₁ (mm)	1150			
DIMENSIONS		4.1	Tilt of mast/fork carriage forward/backward	α / β (°)	1162		
	4.2	Height, mast lowered	h ₁ (mm)	6 / 10			
	4.3	Free lift ⁽¹⁾	h ₂ (mm)	2215			
	4.4	Lift ⁽¹⁾	h ₃ (mm)	100			
	4.5	Height, mast extended ⁽²⁾	h ₄ (mm)	2740			
	4.7	Height of overhead guard (cabin)	h ₆ (mm)	3730			
	4.8	Seat height/stand height ⁽³⁾	h ₇ (mm)	2300			
	4.12	Coupling height	h ₁₀ (mm)	1321			
	4.19	Overall length	l ₁ (mm)	0			
	4.20	Length to face of forks (Standard Carriage)	l ₂ (mm)	4541			
	4.20.1	Length to face of forks (Integrated Side Shift Carriage)	l ₂ (mm)	3341			
	4.21	Overall width (single / wide / dual)	b ₁ /b ₂ (mm)	3358			
	4.22	Fork dimensions ISO 2331	s/e/l (mm)	1450 / 1575 / 1875			
	4.23	Fork carriage ISO 2328, class/type A, B		60 / 150 / 1200			
	4.24	Fork carriage width (Standard Carriage) ⁽⁴⁾	b ₃ (mm)	IVA			
	4.24.1	Fork carriage width (ISS Carriage) ⁽⁴⁾	b ₃ (mm)	0			
	4.31	Ground clearance, laden, below mast	m ₁ (mm)	1372			
	4.32	Ground clearance, centre of wheelbase	m ₂ (mm)	194			
	4.33	Load dimension b ₁₂ × l ₆ crossways	b ₁₂ × l ₆ (mm)	237			
	4.34	Aisle width predetermined load dimensions ⁽⁵⁾	Ast (mm)	1200 x 1000			
	4.34.1	Aisle width for pallets 1000 × 1200 crossways ⁽⁵⁾	Ast (mm)	4706			
	4.34.2	Aisle width for pallets 800 × 1200 crossways ⁽⁵⁾	Ast (mm)	4906			
	4.35	Turning radius	Wa (mm)	2915			
4.36	Internal turning radius	b ₁₃ (mm)	800				
4.36.1	90° intersecting aisle (with pallet W = 1200mm x L = 1000mm)	(mm)	2490				
4.36.2	Step Height (from ground to running board)	(mm)	441				
4.36.3	Step Height (between intermediate steps and floor)	(mm)	360				
PERFORMANCE	5.1	Travel speed, laden/unladen	km/h	16.2 / 17.5	18.1 / 21.2	16.2 / 17.5	18.1 / 21.2
	5.1.1	Travel speed, laden/unladen, backwards	km/h	16.2 / 17.5			
	5.2	Lift speed, laden/unladen	m/s	0.45 / 0.49			
	5.3	Lowering speed, laden/unladen	m/s	0.51 / 0.42			
	5.5	Drawbar pull, laden/unladen ⁽⁶⁾	N	27620/17976	33078/17976	27620/17976	33078/17976
	5.7	Gradeability, laden/unladen ⁽⁷⁾	%	22/24.8	26.6/24.8	22/24.8	26.6/24.8
	5.9	Acceleration time, laden/unladen	s	6.5/5.2	6.5/5.3	6.5/5.2	6.5/5.3
	5.10	Service brake		Hydraulic			
	ENGINE	7.1	Engine manufacturer/type	Kubota V3600 IDI-T			
		7.2	Engine power according to ISO 1585	kW	57		
7.3		Rated speed	min-1	2400			
7.3.1		Torque at 1/min	Nm/min-1	296 / 1600			
7.4		Number of cylinders/displacement	cm3	4 / 3620			
7.5		Fuel consumption according to VDI cycle	l/h or kg/h	7.2	7.7	7.2	7.7
7.10		Battery voltage/nominal capacity ⁽⁸⁾	V/Ah	12 / 105			
OTHER	8.1	Type of drive unit	Hydrodynamic				
	10.1	Operating pressure for attachments	bar	155			
	10.2	Oil volume for attachments ⁽⁹⁾	l/min	83.3			
	10.3	Hydraulic oil tank, capacity	l	67.8			
	10.4	Fuel tank, capacity	l	100.3			
	10.7	Sound pressure level at the driver's seat ^{(10) (11)}	dB (A)	81			
	10.7.1	Sound power level during the workcycle ⁽¹²⁾	dB (A)	101			
	10.7.2	Guaranteed sound power 2001/14/EC	dB (A)	105			
	10.8	Towing coupling, type DIN		Pin			

(1) Top of forks

(2) Add 32mm with load backrest

(3) Full suspension seat in depressed position

(4) Without load backrest, add 32mm with load backrest

(5) Stacking aisle width (lines 4.34 & 4.34.1 & 4.34.2) are based on the V.D.I. standard calculation as shown on illustration. The British Industrial Truck Association recommends the addition of 100 mm to the total clearance (dimension a) for extra operating margin at the rear of the truck

(6) At 1.6 km/h

(7) At 4.8km/h. Gradeability figures are provided for comparison of tractive performance, but are not intended to endorse the operation of the vehicle on the stated inclines. Follow instructions in the operating manual regarding operation on inclines

(8) Battery ampere hour (Ah) nominal capacity ratings are estimated

(9) Variable

(10) With and without cab

(11) LPAZ, Measured according to the test cycles and based on the weighting values contained in EN12053

(12) LWAZ, Measured according to the test cycles and based on the weighting values contained in EN12053

MAST DIMENSIONS – GDP/GLP 40VX5, GDP/GLP 40VX6

h ₁ (mm)	h _{2+s} (mm) ⁽¹⁾	h _{3+s} (mm)	h ₄ (mm) ⁽¹⁾	h ₄ (mm) ⁽²⁾	Tilt		Superelastic tyres									
							GDP/GLP 40VX5					GDP/GLP 40VX6				
							Forks		Integral Sideshift			Forks		Integral Sideshift		
							Load centre (kg)									
F	B	500	600	700	500	600	700	600	700	600	700					
2-Stage Limited Free-Lift (LFL) Mast																
2175	150	3050	3815	4300	6	10	4000	3670	3580	4000	3670	3470	4000	3890	4000	3770
2475	150	3650	4415	4900	6	10	4000	3670	3570	4000	3670	3460	4000	3870	4000	3750
2775	150	4250	5015	5500	6	10	4000	3670	3550	4000	3670	3440	4000	3860	4000	3740
3225	150	4950	5715	6200	6	6	3880	3560	3430	3880	3560	3320	3890	3720	3890	3610
2-Stage Full Free-Lift (FFL) Mast																
2175	1355	3075	3890	4325	6	10	4000	3670	3450	4000	3670	3400	4000	3750	4000	3690
2475	1655	3675	4490	4925	6	10	4000	3670	3440	4000	3650	3380	4000	3730	3990	3670
3-Stage Full Free-Lift (FFL) Mast																
2175	1355	4415	5225	5665	6	6	4000	3670	3430	3970	3630	3350	4000	3720	3950	3640
2375	1555	4950	5765	6200	6	6	3880	3560	3310	3840	3510	3230	3880	3600	3820	3520
2475	1655	5250	6065	6500	6	6	3800	3490	3240	3760	3440	3170	3810	3530	3740	3450
2575	1755	5550	6365	6800	6	6	3730	3420	3170	3670	3360	3090	3740	3450	3660	3370
2775	1955	6000	6815	7250	6	6	3600	3290	3050	3530	3230	2980	3620	3330	3530	3250

(1) Without load backrest

(2) With load backrest

MAST DIMENSIONS – GDP/GLP 45SVX5, GDP/GLP 45VX6

h ₁ (mm)	h _{2+s} (mm) ⁽¹⁾	h _{3+s} (mm)	h ₄ (mm) ⁽¹⁾	h ₄ (mm) ⁽²⁾	Tilt		Superelastic tyres									
							GDP/GLP 45SVX5					GDP/GLP 45VX6				
							Forks		Integral Sideshift			Forks		Integral Sideshift		
							Load centre (kg)									
F	B	500	600	700	500	600	700	600	700	600	700					
2-Stage Limited Free-Lift (LFL) Mast																
2215	160	2800	3730	4065	6	10	4500	4000	3890	4440	4000	3770	4500	4340	4500	4210
2515	160	3400	4330	4665	6	10	4500	4000	3870	4420	4000	3750	4500	4330	4500	4200
2815	160	4000	4930	5265	6	10	4500	4000	3860	4410	4000	3740	4500	4310	4500	4180
3265	160	4700	5630	5965	6	6	4380	3900	3730	4260	3900	3620	4390	4180	4390	4060
3665	160	5300	6230	6565	6	6	4230	3760	3580	4090	3750	3470	4250	4030	4230	3910
4065	160	5900	6830	7165	6	6	4040	3620	3420	3900	3580	3310	4100	3860	4050	3740
2-Stage Full Free-Lift (FFL) Mast																
2215	1230	2825	3810	4090	6	10	4500	4000	3860	4410	4000	3740	4500	4310	4500	4180
2515	1530	3425	4410	4690	6	10	4500	4000	3840	4390	4000	3720	4500	4290	4500	4170
3-Stage Full Free-Lift (FFL) Mast																
2215	1230	4145	5130	5415	6	6	4500	4000	3820	4370	4000	3700	4500	4270	4490	4150
2515	1530	5000	5985	6265	6	6	4300	3820	3630	4150	3810	3520	4310	4080	4290	3960
2615	1630	5300	6285	6565	6	6	4210	3750	3560	4070	3730	3450	4240	4000	4210	3890

(1) Without load backrest

(2) With load backrest

MAST DIMENSIONS – GDP/GLP 50VX, GDP/GLP 55VX

h ₁ (mm)	h _{2+s} (mm) ⁽¹⁾	h _{3+s} (mm)	h ₄ (mm) ⁽¹⁾	h ₄ (mm) ⁽²⁾	Tilt		Superelastic tyres									
							GDP/GLP 50VX				GDP/GLP 55VX					
							Forks		Integral Sideshift		Forks		Integral Sideshift			
							Load centre (kg)									
F	B	600	700	600	700	600	700	600	700							
2-Stage Limited Free-Lift (LFL) Mast																
2215	160	2800	3730	4065	6	10	5000	4810	5000	4670	5500	5280	5500	5130		
2515	160	3400	4330	4665	6	10	5000	4790	5000	4650	5500	5260	5500	5120		
2815	160	4000	4930	5265	6	10	5000	4780	5000	4640	5500	5250	5500	5100		
3265	160	4700	5630	5965	6	6	4890	4640	4880	4510	5380	5110	5370	4970		
3665	160	5300	6230	6565	6	6	4740	4480	4700	4350	5230	4940	5190	4800		
4065	160	5900	6830	7165	6	6	4570	4300	4520	4170	5050	4750	5000	4620		
2-Stage Full Free-Lift (FFL) Mast																
2215	1230	2825	3810	4090	6	10	5000	4770	5000	4640	5500	5250	5500	5100		
2515	1530	3425	4410	4690	6	10	5000	4760	5000	4620	5500	5230	5500	5080		
3-Stage Full Free-Lift (FFL) Mast																
2215	1230	4145	5130	5415	6	6	5000	4740	4990	4610	5500	5210	5490	5070		
2515	1530	5000	5985	6265	6	6	4800	4530	4770	4410	5290	5000	5260	4860		
2615	1630	5300	6285	6565	6	6	4730	4450	4690	4330	5210	4920	5170	4780		

(1) Without load backrest

(2) With load backrest

All values are nominal values and they are subject to tolerances.

Specification data based on standard carriage, load backrest, and 1000mm (GDP/GLP 40 VX5) / 1200mm (GDP/GLP 40VX6 - GDP/GLP 55VX) forks

MAST DIMENSIONS – GDP/GLP 40VX5, GDP/GLP 40VX6

h ₁ (mm)	h _{2+S} (mm) ⁽¹⁾	h _{3+S} (mm)	h ₄ (mm) ⁽¹⁾	h ₄ (mm) ⁽²⁾	Tilt		Pneumatic radial tyres									
							GDP/GLP 40VX5					GDP/GLP 40VX6				
							Forks		Integral Sideshift			Forks		Integral Sideshift		
							Load centre (kg)									
F	B	500	600	700	500	600	700	600	700	600	700					
2-Stage Limited Free-Lift (LFL) Mast																
2175	150	3050	3815	4300	6	10	4000	3670	3580	4000	3670	3470	4000	3890	4000	3770
2475	150	3650	4415	4900	6	10	4000	3670	3570	4000	3670	3460	4000	3870	4000	3750
2775	150	4250	5015	5500	6	10	4000	3670	3550	4000	3670	3440	4000	3860	4000	3740
3225	150	4950	5715	6200	6	6	3880	3560	3420	3880	3560	3320	3890	3720	3890	3610
2-Stage Full Free-Lift (FFL) Mast																
2175	1355	3075	3890	4325	6	10	4000	3670	3450	4000	3670	3400	4000	3750	4000	3690
2475	1655	3675	4490	4925	6	10	4000	3670	3440	4000	3670	3380	4000	3730	3990	3670
3-Stage Full Free-Lift (FFL) Mast																
2175	1355	4415	5225	5665	6	6	4000	3670	3430	3970	3630	3350	4000	3720	3950	3640
2375	1555	4950	5765	6200	6	6	3870 ⁽³⁾	3550 ⁽³⁾	3310 ⁽³⁾	3830 ⁽³⁾	3510 ⁽³⁾	3230 ⁽³⁾	3880 ⁽³⁾	3600 ⁽³⁾	3820 ⁽³⁾	3520 ⁽³⁾
2475	1655	5250	6065	6500	6	6	3800 ⁽³⁾	3490 ⁽³⁾	3230 ⁽³⁾	3750 ⁽³⁾	3430 ⁽³⁾	3160 ⁽³⁾	3810 ⁽³⁾	3520 ⁽³⁾	3740 ⁽³⁾	3440 ⁽³⁾
2575	1755	5550	6365	6800	6	6	3730 ⁽⁴⁾	3420 ⁽⁴⁾	3170 ⁽⁴⁾	3670 ⁽⁴⁾	3360 ⁽⁴⁾	3090 ⁽⁴⁾	3740 ⁽⁴⁾	3450 ⁽⁴⁾	3660 ⁽⁴⁾	3370 ⁽⁴⁾
2775	1955	6000	6815	7250	6	6	3600 ⁽⁴⁾	3310 ⁽⁴⁾	3050 ⁽⁴⁾	3530 ⁽⁴⁾	3230 ⁽⁴⁾	2980 ⁽⁴⁾	3620 ⁽⁴⁾	3330 ⁽⁴⁾	3530 ⁽⁴⁾	3250 ⁽⁴⁾

(1) Without load backrest

(3) Wide Tread or Dual Drive Wheels Required

(2) With load backrest

(4) Dual Drive Wheels Required. Specification data based on standard carriage, load backrest, and 1000mm (GDP/GLP 40 VX5) / 1200mm (GDP/GLP 40VX6 - GDP/GLP 55VX) forks

MAST DIMENSIONS – GDP/GLP 45SVX5, GDP/GLP 45VX6

h ₁ (mm)	h _{2+S} (mm) ⁽¹⁾	h _{3+S} (mm)	h ₄ (mm) ⁽¹⁾	h ₄ (mm) ⁽²⁾	Tilt		Pneumatic radial tyres									
							GDP/GLP 45SVX5					GDP/GLP 45VX6				
							Forks		Integral Sideshift			Forks		Integral Sideshift		
							Load centre (kg)									
F	B	500	600	700	500	600	700	600	700	600	700					
2-Stage Limited Free-Lift (LFL) Mast																
2215	160	2800	3730	4065	6	10	4500	4000	3890	4440	4000	3770	4500	4340	4500	4210
2515	160	3400	4330	4665	6	10	4500	4000	3870	4420	4000	3750	4500	4330	4500	4200
2815	160	4000	4930	5265	6	10	4500	4000	3860	4410	4000	3740	4500	4310	4500	4180
3265	160	4700	5630	5965	6	6	4380	3890	3730	4260	3890	3610	4390	4180	4390	4060
3665	160	5300	6230	6565	6	6	4230 ⁽³⁾	3760 ⁽³⁾	3570 ⁽³⁾	4080 ⁽³⁾	3750 ⁽³⁾	3460 ⁽³⁾	4240 ⁽³⁾	4020 ⁽³⁾	4220 ⁽³⁾	3900 ⁽³⁾
4065	160	5900	6830	7165	6	6	4040 ⁽⁴⁾	3610 ⁽⁴⁾	3410 ⁽⁴⁾	3900 ⁽⁴⁾	3580 ⁽⁴⁾	3310 ⁽⁴⁾	4080 ⁽³⁾	3840 ⁽³⁾	4030 ⁽³⁾	3730 ⁽³⁾
2-Stage Full Free-Lift (FFL) Mast																
2215	1230	2825	3810	4090	6	10	4500	4000	3860	4410	4000	3740	4500	4310	4500	4180
2515	1530	3425	4410	4690	6	10	4500	4000	3840	4390	4000	3720	4500	4290	4500	4170
3-Stage Full Free-Lift (FFL) Mast																
2215	1230	4145	5130	5415	6	6	4500	4000	3820	4370	4000	3700	4500	4270	4490	4150
2515	1530	5000	5985	6265	6	6	4250 ⁽³⁾	3820 ⁽³⁾	3630 ⁽³⁾	4150 ⁽⁴⁾	3810 ⁽⁴⁾	3520 ⁽⁴⁾	4310 ⁽³⁾	4070 ⁽³⁾	4280 ⁽³⁾	3950 ⁽³⁾
2615	1630	5300	6285	6565	6	6	4210 ⁽⁴⁾	3750 ⁽⁴⁾	3560 ⁽⁴⁾	4070 ⁽⁴⁾	3730 ⁽⁴⁾	3450 ⁽⁴⁾	4230 ⁽³⁾	3990 ⁽³⁾	4200 ⁽³⁾	3880 ⁽³⁾

(1) Without load backrest

(3) Wide Tread or Dual Drive Wheels Required

(2) With load backrest

(4) Dual Drive Wheels Required. Specification data based on standard carriage, load backrest, and 1000mm (GDP/GLP 40 VX5) / 1200mm (GDP/GLP 40VX6 - GDP/GLP 55VX) forks

MAST DIMENSIONS – GDP/GLP 50VX, GDP/GLP 55VX

h ₁ (mm)	h _{2+S} (mm) ⁽¹⁾	h _{3+S} (mm)	h ₄ (mm) ⁽¹⁾	h ₄ (mm) ⁽²⁾	Tilt		Pneumatic radial tyres							
							GDP/GLP 50VX				GDP/GLP 55VX			
							Forks		Integral Sideshift		Forks		Integral Sideshift	
							Load centre (kg)							
F	B	600	700	600	700	600	700	600	700					
2-Stage Limited Free-Lift (LFL) Mast														
2215	160	2800	3730	4065	6	10	5000	4810	5000	4670	5500	5280	5500	5130
2515	160	3400	4330	4665	6	10	5000	4790	5000	4650	5500	5260	5500	5120
2815	160	4000	4930	5265	6	10	5000	4780	5000	4640	5500	5250	5500	5100
3265	160	4700	5630	5965	6	6	4880	4640	4870	4500	5380 ⁽³⁾	5110 ⁽³⁾	5370 ⁽³⁾	4960 ⁽³⁾
3665	160	5300	6230	6565	6	6	4730 ⁽³⁾	4470 ⁽³⁾	4700 ⁽³⁾	4340 ⁽³⁾	5220 ⁽³⁾	4930 ⁽³⁾	5180 ⁽³⁾	4790 ⁽³⁾
4065	160	5900	6830	7165	6	6	4570 ⁽⁴⁾	4300 ⁽⁴⁾	4510 ⁽⁴⁾	4170 ⁽⁴⁾	5050 ⁽⁴⁾	4750 ⁽⁴⁾	4990 ⁽⁴⁾	4610 ⁽⁴⁾
2-Stage Full Free-Lift (FFL) Mast														
2215	1230	2825	3810	4090	6	10	5000	4770	5000	4640	5500	5250	5500	5100
2515	1530	3425	4410	4690	6	10	5000	4760	5000	4620	5500	5230	5500	5080
3-Stage Full Free-Lift (FFL) Mast														
2215	1230	4145	5130	5415	6	6	5000	4740	4990	4610	5500	5210	5490	5070
2515	1530	5000	5985	6265	6	6	4800 ⁽³⁾	4530 ⁽³⁾	4760 ⁽³⁾	4400 ⁽³⁾	5290 ⁽³⁾	4990 ⁽³⁾	5260 ⁽³⁾	4860 ⁽³⁾
2615	1630	5300	6285	6565	6	6	4730 ⁽⁴⁾	4450 ⁽⁴⁾	4680 ⁽⁴⁾	4330 ⁽⁴⁾	5210 ⁽⁴⁾	4910 ⁽⁴⁾	5170 ⁽⁴⁾	4780 ⁽⁴⁾

(1) Without load backrest

(3) Wide Tread or Dual Drive Wheels Required

(2) With load backrest

(4) Dual Drive Wheels Required. Specification data based on standard carriage, load backrest, and 1000mm (GDP/GLP 40 VX5) / 1200mm (GDP/GLP 40VX6 - GDP/GLP 55VX) forks

FEATURES LIST – VX SERIES

	STD	OPT
Powertrain protection system		●
Premium monitoring package		●
Hydraulic Accumulator, recommended for use with clamping attachments		●
Keyless start (with Passcode access)		●
Traction speed limiter		●
Swing-out, drop-down EZ-Tank bracket		●
Right hand armrest incorporating AccuTouch mini-lever electrohydraulic controls, direction switch and horn button		●
Return-to-set tilt		●
Swivel full suspension seat		●
Foot directional control		●
Operator password		●
Mirrors - dual side view		●

	STD	OPT
Alarm-reverse actuated 82-102dB(A) - self adjusting		●
Amber strobe light - continuous activated		●
Impact monitor		●
Paper applications kits		●
4 function (2 aux) hydraulic control valve		●
Load weight indicator		●
Cabin and Air Conditioned Cabin		●
Partial Cabins		●
Lowered Overhead Guard and Cabin		●
Yale Vision Telemetry System		●

RATED CAPACITIES – STANDARD CARRIAGE – VX SERIES

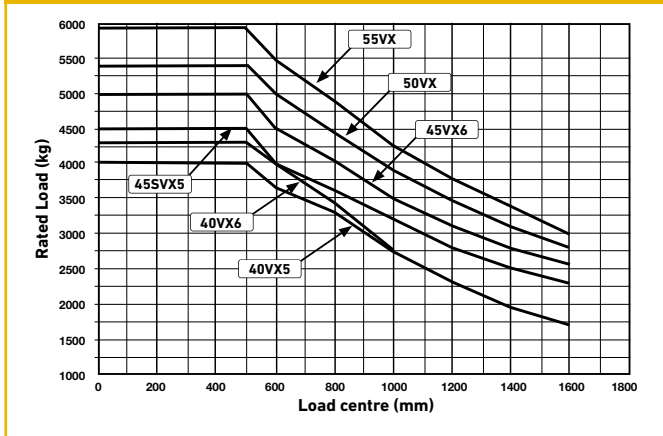

RATED CAPACITIES – ISS – VX SERIES

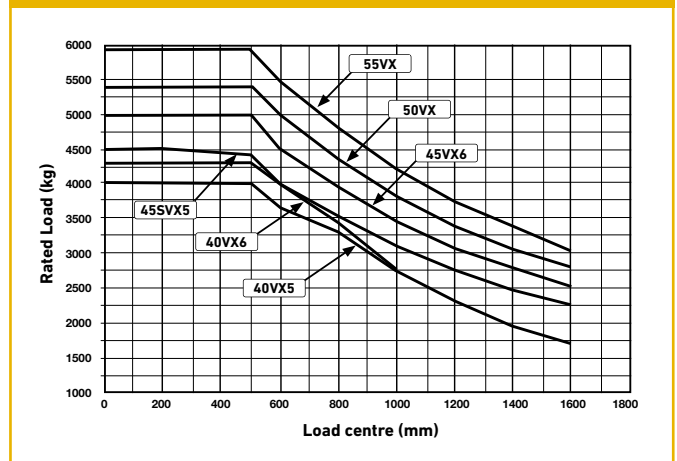

RATED CAPACITIES – STANDARD CARRIAGE – VX SERIES

Load centre (mm)	GDP40VX5 (kg)	GDP40VX6 (kg)	GDP455VX5 (kg)	GDP45VX6 (kg)	GDP50VX (kg)	GDP55VX (kg)
0	4000	4300	4500	5000	5400	5950
200	4000	4300	4500	5000	5400	5950
500	4000	4300	4500	5000	5400	5950
600	3670	4000	4000	4500	5000	5500
800	3310	3450	3610	4030	4460	4900
1000	2760	2760	3150	3520	3900	4280
1200	2300	2300	2800	3130	3460	3800
1400	1970	1970	2520	2810	3110	3420
1600	1720	1720	2290	2560	2830	3000

RATED CAPACITIES – ISS – VX SERIES

Load centre (mm)	GDP40VX5 (kg)	GDP40VX6 (kg)	GDP455VX5 (kg)	GDP45VX6 (kg)	GDP50VX (kg)	GDP55VX (kg)
0	4000	4300	4500	5000	5400	5950
200	4000	4300	4500	5000	5400	5950
500	4000	4300	4440	4970	5400	5950
600	3670	4000	4000	4500	5000	5500
800	3320	3450	3500	3920	4340	4770
1000	2760	2760	3070	3430	3800	4180
1200	2300	2300	2730	3050	3380	3720
1400	1970	1970	2460	2750	3050	3350
1600	1720	1720	2240	2500	2770	3000

All values are nominal values and they are subject to tolerances.

POWERTRAINS – VX SERIES

ENGINE	1.3	Drive		Diesel	LPG SWB	LPG LWB
	7.1	Engine manufacturer/type		Kubota V3800 DICR-T-E4	Kubota WG3800	
	7.2	Engine power according to ISO 1585	kW	55	54.9	64
	7.3	Rated speed	min-1	2200	1800	2200
	7.3.1	Torque at 1/min	Nm/min-1	300 / 1400	300 / 1200	
	7.4	Number of cylinders/displacement	cm3	4 / 3769		
	7.10	Battery voltage/nominal capacity ⁽¹⁾	(V)/(Ah)	12 / 105		
OTHER	8.1	Type of drive unit		Hydrodynamic		
	8.2	Manufacturer/type		NMHG/Electronic		
	8.6	Wheel drive/drive axle manufacturer/type		Dana/WBA		
	8.11	Service brake		Multi Disc Brake		
	8.12	Parking brake		Multi Disc Brake		

(1) Battery ampere hour (Ah) nominal capacity ratings are estimated

ENGINE SPECIFICATIONS – VX SERIES

Kubota WG3800		Kubota V3800 E4		Kubota V3600 IDI-T	
CE Compliance / Emission Standard	Stage V Compliant	CE Compliance / Emission Standard	Stage V Compliant with Diesel Oxidisation Catalyst (DOC) or Diesel Particulate Filter (DPF) as standard	CE Compliance / Emission Standard	IIIA
Cylinders	Inline 4	Cylinders	Inline 4	Cylinders	Inline 4
Displacement	3.769 litre	Displacement	3.8 litre	Displacement	3.62 litre
Torque	300Nm @ 1,000rpm	Torque	309.0Nm @ 1,400rpm	Torque	296Nm
Power SWB	54.9kW @ 1,800rpm	Power	55.0kW @ 2,200rpm	Power	55.0kW @ 2,200rpm
Power LWB	64.0kW @ 2,200rpm				

All values are nominal values and they are subject to tolerances.



Glenview
Hillstreet Quarries Ltd
Arigna
Carrick-on-Shannon
Co. Roscommon
Ireland.
Tel. + 353 71 96 46017
Fax. + 353 71 96 46291
www.glenviewworld.com
enquiries@glenviewworld.com

Glenview
Hillstreet Quarries Ltd
Arigna
Carrick-on-Shannon
Co. Roscommon
Ireland.
Tel. + 353 71 96 46017
Fax. + 353 71 96 46291
www.glenviewworld.com
enquiries@glenviewworld.com



About Yale®

Yale Materials Handling Corporation is one of the oldest manufacturers of lift trucks in the world. We've been in the business of lifting since 1875 and we apply that experience to help customers solve materials handling challenges. Our full line of lift trucks range in capacity from 1 to 16 tonne and are powered by internal combustion engines or electric options. Yale also offers robotic solutions, telemetry, fleet management, parts, financing and training. From traditional lift truck equipment to emerging technologies, our goal, every day, is to work with our nationwide dealer network to continually improve and provide the solutions you need, when and how you need them.

MATERIALS HANDLING FOR:

3PL

Auto Parts

Beverage

Cold & Frozen Foods

Food Distribution

Food Processing

Furniture & Furnishings

Health & Pharma

Home Centres

Retail

E-Commerce

Yale Lift Truck Technologies

Centennial House
Frimley Business Park
Frimley
Surrey
GU16 7SG
United Kingdom

www.yale.com



Safety: All Yale products sold into EU countries, UK, and Turkey conform to the EU requirements of Machinery Directive 2006/42/EC and contain **CE** marking. Yale trucks sold into other countries may be ordered for production in conformance with Machinery Directive requirements, and when so ordered will contain **CE** marking.

HYSTER-YALE UK LIMITED trading as Yale Lift Truck Technologies. Registered Address: Centennial House, Building 4.5, Frimley Business Park, Frimley, Surrey, GU16 7SG, United Kingdom. Registered in England and Wales. Company Registration Number: 02636775.

©2023 Hyster-Yale Group, Inc., all rights reserved. YALE and YALE  are trademarks of Hyster-Yale Group, Inc. Trucks may be shown with optional equipment and/or features not available in all regions. Truck performance may be affected by the condition of the vehicle, how it is equipped and the application. Specifications are subject to change without notice.

Notice: Care must be exercised when handling elevated loads. Operators must be trained and must read, understand and follow the instructions contained in the Operating Manual. Consult your Yale® Dealer if any of the information shown is critical to your application.

Publication part no. 220991948 Rev.00 (0323DMS) EN